

**KNOWLEDGE
FOR A BRIGHTER
FUTURE**

Guidelines for the welded fabrication of nickel alloys for corrosion-resistant service

A PRACTICAL GUIDE FOR
WELDERS, MATERIAL ENGINEERS
AND DESIGN ENGINEERS

Guidelines for the welded fabrication of nickel alloys for corrosion-resistant service

A PRACTICAL GUIDE

Second Edition

Published 2018

The material presented in this publication has been prepared for the general information of the reader and should not be used or relied on for specific applications without first securing competent advice.

The Nickel Institute, its members, staff and consultants do not represent or warrant its suitability for any general or specific use and assume no liability or responsibility of any kind in connection with the information herein.

This report was prepared by:
Richard E. Avery
Consultant to the Nickel Institute.
Technical Editor: Geir Moe

Contents

Introduction	7		
PART I – For the welder	9	PART III – For the design engineer	39
Physical properties of nickel alloys.....	9	Design for corrosion service	39
Corrosion resistance of nickel alloy welds	9	Weld overlay, sheet lining, and clad plate	43
Welding qualifications.....	11	Weld overlay	44
Welding procedure specification	11	SAW; GMAW; SMAW; Weld overlay guidelines	
Welder performance qualification and training.....	12	Sheet lining.....	45
Weld joint design.....	12	Clad plate	45
Preparation for welding	13	Safety and welding fumes	49
Welding processes	17	Reference documents	51
Shielded metal arc welding (SMAW).....	17		
Gas tungsten arc welding (GTAW).....	19		
Gas metal arc welding (GMAW).....	22		
Flux cored arc welding (FCAW)	23		
Submerged arc welding (SAW)	23		
Other welding processes	24		
Welding nickel alloy pipe	24		
Post-fabrication cleaning	27		
PART II – For the materials engineer	29		
General guidelines for nickel alloys	29		
Group I - Nickel and nickel-copper alloys	30		
Group II - Chromium-bearing alloys.....	31		
Group III - Nickel-molybdenum alloys	31		
Group IV - Precipitation-hardening nickel alloys	32		
Dissimilar-metal welds	32		
Procurement guidelines.....	33		
Nickel alloy castings	33		
Source Inspections	35		
<i>radiographic inspection; liquid penetrant inspection;</i>			
<i>weldability test; pressure test; certification; heat</i>			
<i>treatment; chemistry</i>			
Casting repair by welding.....	37		
Welding nickel alloy castings	37		
Procurement checklist for nickel alloy castings	38		

Tables

Table 1	Wrought nickel alloys by group	9
Table 2	Influence of physical properties on welding nickel alloys.	10
Table 3	Nickel alloy cutting methods	14
Table 4	Embrittling elements	14
Table 5	Matching composition filler metals for nickel alloys	18
Table 6	Comparison of GMAW arc modes for nickel alloys	23
Table 7	Nominal composition of significant elements of Groups I-IV wrought nickel and nickel alloys	30
Table 8	Nominal composition of cast corrosion resistant nickel alloys	31
Table 9	Matching filler metals of the comparable solid solution alloys	32
Table 10-A	Filler metal alloy identification for bare and covered electrodes	33
Table 10-B	Suggested filler metals for dissimilar metal welds	34
Table 11	Specifications for procurement of wrought nickel and nickel alloys	35
Table 12	Comparisons of weld overlay, sheet lining, and clad plate	44

Figures

Figure 1	Incomplete fusion in pipe root pass weld.	10	Figure 25	Corner weld from inside—poor inside, worst outside	40
Figure 2-1	Typical joint designs for sheet and plate.	12,13	Figure 26	Corner weld from both sides—poor inside, good outside.	40
Figure 3	Sample showing sulphur embrittlement of a Nickel 200 sheet	15	Figure 27	Side wall in lieu of corner weld—best inside, good outside, fatigue resistant	40
Figure 4	Typical backing bar designs for use with and without a backing gas	16	Figure 28	Tray support, staggered strength weld—severe crevice.	41
Figure 5	Tack weld sequence to provide uniform weld gap.	17	Figure 29	Tray support, full seal weld top—good crevice resistance	41
Figure 6	The arc zone in the SMAW process	17	Figure 30	Tray support, full seal weld top & bottom—best crevice resistance	41
Figure 7	The Gas Tungsten Arc Weld (GTAW) process.	20	Figure 31	Reinforcing pad, staggered welds—adequate strength	41
Figure 8	The basic components of the Gas Metal Arc Weld (GMAW) process.	22	Figure 32	Reinforcing pad, seal weld—best crevice resistance	41
Figure 9	Typical joint design for pipe with consumable insert.	25	Figure 33	Position of angles.	41
Figure 10	Typical joint design for pipe welded with open root joint and hand-fed filler metal	25	Figure 34	Position of angles.	41
Figure 11	Standard consumable insert shapes, ANSI/AWS D10.11.	26	Figure 35	Position of channels	41
Figure 12	Typical pipe purging fixtures	26	Figure 36	Stiffeners and baffles.	42
Figure 13	Flat bottom, square corners—worst	39	Figure 37	Corner baffle cut-out—good	42
Figure 14	Flat bottom, rounded corners—good corners—poor outside	39	Figure 38	Heat exchanger, baffle cut-out—good	42
Figure 15	Flat bottom, rounded corners, grouted—good inside, poor outside.	39	Figure 39	Poor and good designs for the location of heaters in a vessel.	42
Figure 16	Flat bottom, rounded corners, drip skirt—good inside, good outside	39	Figure 40	Poor and good designs for mixing concentrated and dilute solutions	42
Figure 17	Concave bottom rounded corners—good inside, good outside, fatigue resistant	39	Figure 41	Pipe weld with incomplete penetration—severe crevice.	43
Figure 18	Dished head—best inside, best outside, fatigue resistant	39	Figure 42	Pipe recessed, flange and pipe, same alloy—good	43
Figure 19	Side outlet above bottom—poor	40	Figure 43	Pipe flush, pipe and flange same alloy—better.	43
Figure 20	Centre outlet, above bottom—poor.	40	Figure 44	Stub-end, flange carbon steel or ductile iron—very good.	43
Figure 21	Side outlet, flush—good	40	Figure 45	(A) Horizontal (standard)—poor	43
Figure 22	Centre outlet recessed—good	40		(B) Sloped)—very good	43
Figure 23	Side outlet, flush, sloped—best.	40	Figure 46	Weld joints for liners	46
Figure 24	Centre outlet, recessed, sloped—best.	40	Figure 47	Joint designs for clad steel	46

Introduction

This publication is presented in three parts with each, in turn, focused toward the primary interests of the welder, the materials engineer, and the design engineer.

Part I, FOR THE WELDER, assumes that the welders and others involved in welded fabrication are familiar with the basic techniques used in carbon steel fabrication and have had limited experience with nickel alloys. The discussion treats many areas of concern to the welder and gives practical suggestions concerning the effects of shop practices in maintaining the corrosion resisting properties of the nickel alloys. The importance of proper storage and protection of the surfaces, proper cleaning combined with the proper cleaning materials is stressed both before and after welding. Welding and welding training and qualification are discussed as well as arc management during the welding process. A number of commonly used welding processes are covered to furnish a perspective of the particular features that ensure improved results. Finally, the particular considerations involved in welding pipe are discussed. Part I takes a “how to” approach useful to the non-engineer but the material covered is also a good reference for the materials and design engineer.

Part II, FOR THE MATERIALS ENGINEER, describes the types of nickel alloys; it reviews how their metallurgical and corrosion characteristics are affected by welding and covers some of the more specialised aspects of fabrication such as heat treating. A number of useful references are included to assist in the selection of electrodes, rods, and filler metals for solid solution alloys. Additional tables cover the selection of electrodes and rods for dissimilar metal welds. Guidelines are included for material procurement of castings along with suggestions for supplementing the specifications with additional requirements and tests to assure the quality of the finished castings.

Part III, FOR THE DESIGN ENGINEER, provides a number of design examples showing how the corrosion performance of nickel alloys used in process tanks can be enhanced through thoughtful design. A generous number of figures illustrate the configurations which improve the prospects for successful performance in corrosive environments. The discussion also treats weld overlay, sheet lining, and clad plate as alternative means of providing corrosion protection using nickel alloys. A number of welding processes are briefly evaluated as tools for achieving the desired results with each of these alternates.

Part I

For the welder

Part I focuses on the fabrication and welding of nickel alloys as they relate to the welders and production personnel engaged in fabrication of nickel alloys for corrosion service. *Table 1* shows the wrought and cast nickel alloys by group.

Physical properties of nickel alloys

The physical properties of solid solution nickel alloys, Groups I, II, and III, are quite similar to the 300 Series austenitic stainless steels. The solid solution nickel alloys cannot be strengthened by heat treatment, only by cold working. Group IV alloys, the precipitation hardening nickel alloys, are strengthened by special heat treatments similar to those for the precipitation

hardening (PH) stainless steels. While the solid solution alloys, Groups I, II, and III are predominately used for corrosion-resistant services, the Group IV alloys are used where higher strength is needed, although with usually some small sacrifice of corrosion resistance. Some physical properties and their influence on welding are shown in *Table 2*.

Corrosion resistance of nickel alloy welds

The performance of nickel alloy equipment in corrosive service is subject to the care taken by welders and others on the shop floor. Sound, high-quality welds are the single most important objective; however, to achieve this objective,

Table 1 Nickel alloys by group					
Wrought alloys		Wrought alloys		Cast alloys ASTM A494	
Alloy	UNS No.	Alloy	UNS No.	Alloy	UNS No.
Group I - Nickel and nickel-copper solid solution alloys					
200	N02200	400	N04400	CZ-100	N02100
201	N02201	R-405	N04405	M-35-1	N24135
Group II - Chromium-bearing solid solution alloys					
825	N08825	59	N06059	CW-6MC	N26625
G-3	N06985	2000	N06200	CY-40	N06040
G-30	N06030	C-22/622	N06022	CW-2M	N26455
600	N06600	C-4	N06455	CX-2MW	N26022
690	N06690	C-276	N10276		
625	N06625	33	R20033		
686	N06686				
Group III - Nickel-molybdenum alloys					
B-2	N10665	B-4	N10629	N-7M	J30007
B-3	N10675			N-3M	J30003
Group IV - Precipitation hardening alloys (used for corrosive service)					
K-500	N05500	725	N07725		
625 PLUS®	N07716	718	N07718		

Table 2 Influence of physical properties on welding nickel alloys

Property	Alloy(s)	Remarks
Melting point	All	Melting point is 55 °-165 °C (100-300 °F) lower than SAE 1020 steel, tending to allow faster welding for the same heat or less heat for the same speed.
Magnetic response	Nickel 200, 201	Magnetic up to 360 °C (680 °F), subject to arc blow similar to carbon steels.
	400, R-405	May be magnetic or non-magnetic at room temperature, depending on composition variations
	All others	Non-magnetic similar to austenitic stainless steels
Electrical resistance	Nickel 200, 201	Low, similar to SAE 1020 steel.
	Others	Varies with composition. Compared to Type 304, alloy 400 is 25% lower while the chromium-bearing alloys are up to 200% higher. High electrical resistance may cause overheating in some covered electrodes.
Thermal expansion	All	All nickel alloys are closer to carbon steels than are the austenitic stainless steels. This results in less warpage and distortion than comparable stainless steel fabrications and lower residual stresses in welding to low alloy steels.

Note: While wrought austenitic stainless steels are non-magnetic, some stainless welds and castings may be slightly magnetic because of the presence of delta ferrite. Nickel-chromium and nickel-chromium-iron wrought and cast alloys do not contain ferrite and do not exhibit a magnetic response.

there are a number of factors that require attention during fabrication. These factors will be addressed in detail.

Avoid crevices

It is well-recognised that butt welds should be full-penetration welds to provide optimum strength. In corrosion service, there is another reason for full penetration welds. Crevices resulting from inadequate penetration, when exposed to certain corrosive environments, are potential sites for crevice corrosion. Avoiding crevices is mainly a design responsibility, but it is helpful for those actually making the equipment to assist in eliminating crevices wherever possible. A typical example of an undesirable crevice resulting from incomplete fusion of a pipe root pass weld is shown in *Figure 1*.

Embedded iron

When new nickel alloy equipment develops rust spots, it is almost always the result of embedded free iron. Surface

Figure 1 Incomplete fusion in pipe root pass weld

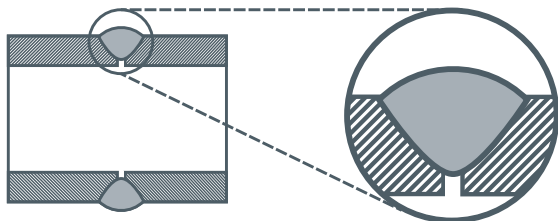

rusting is objectionable from an appearance point of view and might also be the cause of pitting corrosion as it is with austenitic stainless steels in certain environments. Furthermore, the iron or rust may act as a contaminant in the process that it services, thus affecting the product purity.

Following are a few common-sense precautions that can greatly reduce the chances of contamination.

- Protect iron and steel surfaces that might come into intimate contact with nickel alloys by using wood, plastic, or cardboard to prevent iron contamination.
- Use clean stainless steel wire brushes or abrasive disks or wheels that have never been used on iron or steel. Iron-contaminated wire brushes or abrasive disks may introduce embedded iron to the nickel alloy surface.
- Do not leave nickel alloy sheets or plates on the floor where they are exposed to traffic. Store sheet and plate stock in a vertical position.
- Separate nickel alloy and stainless steel fabrication from other types of metal fabrication. Steel grinding, cutting, and blasting operations can introduce embedded iron to the nickel alloy surfaces.

The detection and treatment of embedded iron is discussed under the topic entitled Post-fabrication cleaning, later in this section.

Effect of surface oxides from welding

It is a well-established fact that heat tint may reduce the

pitting and crevice corrosion resistance of austenitic stainless steels in some environments. Surface oxides in the form of heat tint result from welding on the reverse side of a plate or sheet or from the oxide formed in the heat affected zone (HAZ) next to the weld surface. For example, oxides that form on the inside of a vessel from welding lifting lugs, stiffeners, or similar items, on the outside can be particularly damaging. Such oxides should be removed down to clean metal.

Studies by Silence and Flasche have shown that there is less need for heat tint removal from chromium-containing nickel alloys than from austenitic stainless steels. The tests were made on three nickel alloys and three iron-base alloys using a range of flue gas desulphurisation (FGD) environments representative of oxidising, reducing, and oxidising acid-chloride conditions. These findings are in general agreement with field experience. However, cases have been encountered in non-FGD environments where heat tint removal was essential to corrosion-resistance in nickel-chromium-molybdenum alloys. Such cases are infrequent but do suggest that the best practice is to remove heat tint on the wetted side of the fabrication, whether it occurs on the welded side or on the side opposite the welded surface where lugs or stiffeners may be welded to the outer surface of a tank.

Data on the effect of surface films on the non-chromium-bearing nickel alloys is even more sparse. In the absence of such data for the wide range of potentially corrosive environments where nickel alloys are applied, the conservative approach is to provide the cleanest and most oxide-free surfaces that are economically practical.

Other welding-related defects

A number of additional welding-related defects and their suggested treatments follow:

- Arc strikes on the parent material damage the alloy's protective film and create crack-like imperfections. Weld stop points may create pinpoint defects in the weld metal. Both imperfections can be avoided by using proper techniques and, if they occur, should be removed by light grinding with clean, fine-grit abrasive tools.
- Weld spatter creates a tiny weld where the molten slug of metal touches and adheres to the surface. The protective film is penetrated and tiny crevices are created where the film is weakened.
- Weld spatter can easily be eliminated by applying a commercial spatter-prevention paste to either side of the joint to be welded. The paste and spatter are washed off during cleanup.
- Some nickel alloy electrode coatings contain fluorides which can leach out and cause corrosion if the slag is not completely removed. Slag particles can also create crevices, additional places for corrosion to begin. Slag may be difficult to remove, particularly small particles, when there is a slight undercut or other irregularity. The usual removal is done with wire brushing, light grinding, or abrasive blasting with iron-free abrasives.

Welding qualifications

Welding procedure specification

It is standard practice for fabricators of process equipment to develop and maintain Welding Procedure Specifications (WPS) for the various types of welding. The individual welders and welding operators are tested and certified by satisfactorily making acceptable qualification weldments. There are a number of society or industry codes that govern welding qualifications, but the two most widely used in the North America for corrosion-resistance equipment are:

- American Society of Mechanical Engineers, ASME Boiler and Pressure Vessel Code - Section IX, Welding and Brazing Qualification;
- American Welding Society, Specification for Welding Procedure and Performance Qualification - AWS B2.1

Each country typically has its own individual codes or standards. Fortunately, there is a trend toward the acceptance and interchange of specifications in the interest of eliminating unmerited requalification.

The identification of essential variables that establish the need for a new procedure qualification test is a common element of these codes. These essential variables differ for each welding process; however, they also share some common factors. Changes in any of the following items are considered to be essential changes.

- base metal (P-Number);
- filler metal (F-Number);
- metal thickness;
- shielding gas;
- welding process.

ASME Section IX classification of P-Numbers is often the first determinant as to whether a separate WPS is needed. A change in a base metal from one P-Number to another P-Number requires requalification. Joints made between two base metals of different P-Numbers require a separate WPS, even though qualification tests have been made for each of the two base metals welded to themselves. The P-Numbers of common nickel alloys follow.

P-Number	Base metal
41	Nickel 200, 201
42	Alloy 400
43	600, 690, 625, C-22/622, C-4, C-276, 59, 686, 2000
44	B-2, B-3, B-4
45	825, G-3, G-30, Alloy 33

Not all alloys have been assigned a P-Number. For example, cast alloys and the precipitation hardening alloys Group IV, may not have P-Numbers. Alloys without a P-Number require individual qualification even though similar in composition to an alloy already qualified. If an alloy is not listed in the P-Number tables, the alloy manufacturer can advise if a P-Number has been recently assigned.

Welder performance qualification and training

In complying with welding specification codes such as ASME and AWS, welders must pass a performance test. A welding training program is very beneficial in preparing welders for the performance test and training is equally essential to assure quality production over the long term.

Ample training and practice time should be provided for welders who have not had experience with the particular nickel alloys. For example, the welding characteristics of chromium-bearing solid solution nickel alloys, Group II, are similar to those of austenitic stainless steels. Skilled stainless steel welders can usually adjust quickly to welding Group II alloys. The same welders, however, may find Nickel 200 and Alloy 400 welding fillers a little challenging because of the sluggish nature of the molten weld metal. However, with a little practice, they are usually able to proceed confidently and productively to make high quality welds.

In addition to the particular base metal and welding process, training should include information and practice for unusual

welding positions as well as on the shapes to be welded such as pipe and thin sheets.

Weld joint design

Butt welds should be complete joint penetration welds to produce full strength and optimum performance in corrosion service. Fillet welds need not be complete joint penetration welds as long as the sides and ends are welded to seal off voids that might collect product. Pipe welds that lack complete joint penetration invite crevice corrosion and furthermore creates a high stress point at the root. For this reason, pipe welds should be full-penetration welds for best performance.

Molten nickel alloy weld metal is considerably less fluid than carbon steel and somewhat less fluid than stainless steel. The depth of weld penetration is also not as great. Within the nickel alloy group, there is a difference in fluidity and weld penetration depending upon the amount of nickel that is present. For example, commercially pure Nickel 200/201 is most viscous and yields a shallow weld bead. To compensate for these features, nickel alloy joints have a wider bevel, narrower root face, and wider root opening. The welding process also influences weld joint dimensions. For example, a spray arc gas metal arc weld (GMAW) has a deeper penetration weld bead than other arc welding processes so thicker root faces may be used.

Typical joint designs for sheet and plate are shown in *Figure 2-1* through *2-5*.

Figure 2-1 Typical square butt joint for sheet

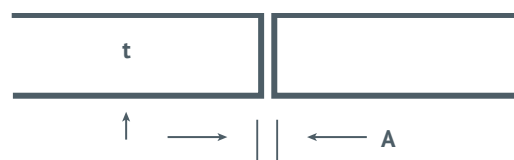

Maximum $t = 3.2 \text{ mm (0.125 in.)}$
 Gap $A = 0.8 \text{ mm min., } 2.3 \text{ mm max}$
 $(0.03\text{--}0.093 \text{ in.})$

Figure 2-2 Typical single "V" joint for sheet and plate.

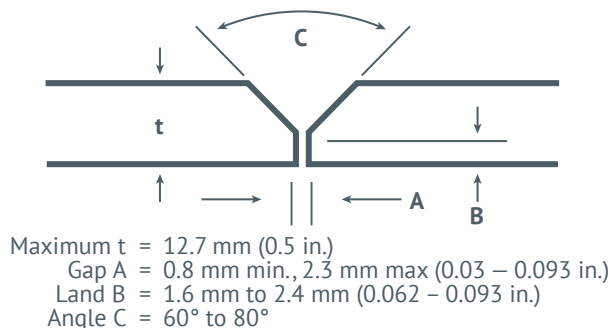

Figure 2-3 Typical double "V" joint for plate.

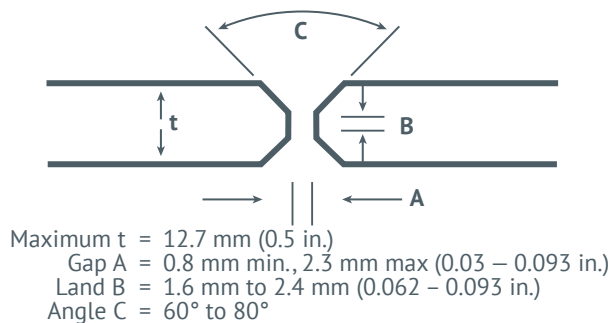

Figure 2-4 Typical single "U" joint for plate.

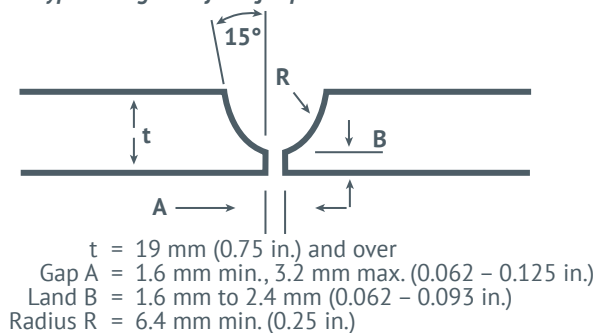
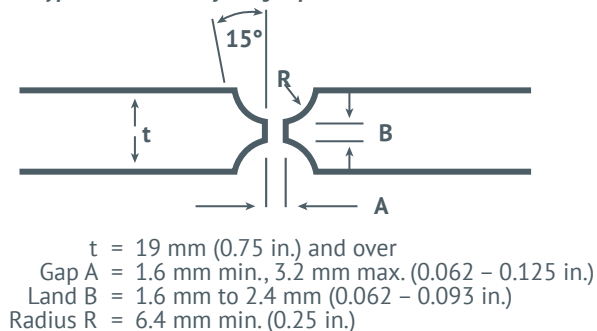

Figure 2-5 Typical double "U" joint for plate.



Preparation for welding

The care taken in preparation for welding is time that yields improved weld quality and a finished product that gives optimum service. Important preparation steps follow.

Cutting and joint preparation

Nickel alloys are cut as shown in *Table 3*. They share the same cutting methods as those used for stainless steels. Oxyacetylene cutting of nickel alloys (without iron-rich powder additions) results in the formation of refractory oxides, preventing accurate, smooth cuts. As evident in *Table 3*, the thickness and shape of the parts being cut largely dictates which of the cutting methods is most appropriate.

Oxides and other surface layers

All oxides and dross from thermal cutting should be removed by grinding, machining, or abrasive blasting. Oxides of elements in nickel alloys such as chromium, nickel and particularly titanium and aluminum in the precipitation hardening alloys, are high melting point oxides and are not fused by the weld metal. An oxide film can become trapped in the solidifying weld, resulting in a defect that is difficult or impossible to detect by radiography.

Surface oxides may be present as a result of heat treating or they may exist on equipment that has been exposed to high temperatures in service. In some high temperature service environments, a carburised or sulphurised surface layer can develop. All such layers should be removed by grinding or machining the area to be welded. Wire brushing does not remove the tightly adhering oxides or other surface layers. While wrought product forms or castings in the as-received condition are normally free of oxides, it is good practice to condition a 25mm (1 in.) wide band on both the top and bottom surface of the weld zone to bright metal with a medium grit flapper wheel or disk.

Surface oxides or a rough surface can have more of an influence on the depth of penetration and bead shape of gas tungsten arc welds (GTAW) than on arc welds made with higher heat input arc welding processes. Pre-weld cleaning of thin gauge sheet or strip, e.g., 0.5 mm (0.020 in.) and thinner, is a critical requirement to prevent weld defects. Vapour blasting is a common cleaning method for this gauge of material.

When repair welding is required on equipment used in chemical service, it is especially important to ensure the removal of surface contamination with careful pre-weld cleaning. The cleaning objective is to remove the embedded contamination by grinding, abrasive blasting, or neutralising the surface prior to repair welding. Acid-contaminated surfaces are neutralised with a mild basic solution and alkaline-contaminated surfaces are neutralised with a mild acid solution. A thorough hot water rinse should always follow the neutralising treatment.

For example, if caustic has been in contact with the nickel alloys for an extended period of time it may have penetrated into the surface. If not removed prior to welding, the weld and heat-affected zone will often develop cracks. Removal requires grinding, abrasive blasting, or neutralising with an acid solution such as 10% (by volume) hydrochloric acid (followed by a thorough hot water rinse).

Contaminating elements

There are a number of elements and compounds that must be removed from the surface prior to welding or heat treating. If not removed, the heat from welding can cause cracking,

weld defects, or reduced corrosion resistance of the weld or HAZ. The elements penetrate at the grain boundaries and the metal is said to be “embrittled”. The elements to be avoided, the type of defect generated, and the common sources of the elements are shown in *Table 4*.

Weld defects, reduced corrosion resistance, or embrittlement are caused by a combination of temperature along with the presence of one of the listed elements. The depth of attack varies with the embrittling element, its concentration, and the heating time and temperature. Group I nickel alloys are most susceptible. *Figure 3* shows a typical example of sulphur embrittlement on a Nickel 200 sheet. The area of an alloy that becomes embrittled cannot be restored and must be discarded. Carbon or carbonaceous materials left on the surface during welding may diffuse into the surface. The resulting high carbon layer lowers the corrosion resistance in many environments.

A number of methods and materials exist for removing the kinds of contaminants mentioned earlier. Metallic contaminants and materials which are not oil or grease-based can be removed by mechanical means such as abrasive blasting

Table 3 Nickel alloy cutting methods

Method	Material thickness	Comments
Shearing	Sheet/strip, thin plate	Prepare edge exposed to environment to remove tear crevices
Sawing & abrasive cutting	Wide range of thicknesses	Remove lubricant or cutting fluid before welding or heat treating
Machining	Wide range of shapes	Remove lubricant or cutting fluid before welding or heat treating
Plasma Arc Cutting (PAC)	Wide range of thicknesses May be used for gouging backside of weld	Grind cut surfaces to clean metal
Powder metal cutting with iron-rich powder	Wide range of thicknesses	Cut less accurate than PAC, must remove all dross
Carbon Arc Cutting	Used for gouging backside of weld and cutting irregular shapes	Grind cut surfaces to clean metal

Table 4 Embrittling elements

Elements	Effect/Defect	Common sources of elements
Sulphur, Carbon	Reduced corrosion resistance	Hydrocarbons such as cutting fluids, grease, oil waxes, and primers
Sulphur, Phosphorous	Cracking in welds and HAZ	Marking crayons, paints, and temperature-indicating markers
Lead, Zinc, Copper (low melting point metals)	Cracking in welds and HAZ	Tools such as lead hammers, copper hold-down or backing bars, zinc-rich paint, galvanised steel
Shop dirt	Any of the above	Any of the above

or light grinding. It is essential that the blasting material or abrasive disk be free of contaminants such as free iron. A nitric acid treatment, followed by neutralisation can effectively remove some low melting point metals without damage to Group II, chromium-bearing alloys, but this treatment may attack other nickel alloys.

Oil or grease based (hydrocarbon-based) contaminants must be removed by solvent cleaning; they are not removed by water or acid solutions. Large weldments are usually hand-cleaned by wiping with solvent-saturated cloths. Other acceptable methods include immersion in, swabbing with, or spraying with alkaline emulsion, solvent, or detergent cleaners, or a combination of these. Vapour degreasing, steam, with or without a cleaner; or high-pressure water jetting can also be utilised. ASTM A380, Standard Practice for Cleaning, Descaling, and Passivating Stainless Steel Parts, Equipment, and Systems, is an excellent guide for fabricators and users.

A typical procedure to remove oil or grease includes the following steps:

- Remove excess contaminant by wiping with clean cloth;
- Swab the weld area at least 5 cm (2 in.) each side of the weld with an organic solvent such as an aliphatic petroleum, a chlorinated hydrocarbon, or blends of the two. (See cautionary remarks which follow.) Use only clean solvent (uncontaminated with acid, alkali, oil, or other foreign material) and clean cloths;

Figure 3 Nickel 200 welded sheet showing sulphur embrittlement on the right side caused by inadequate cleaning

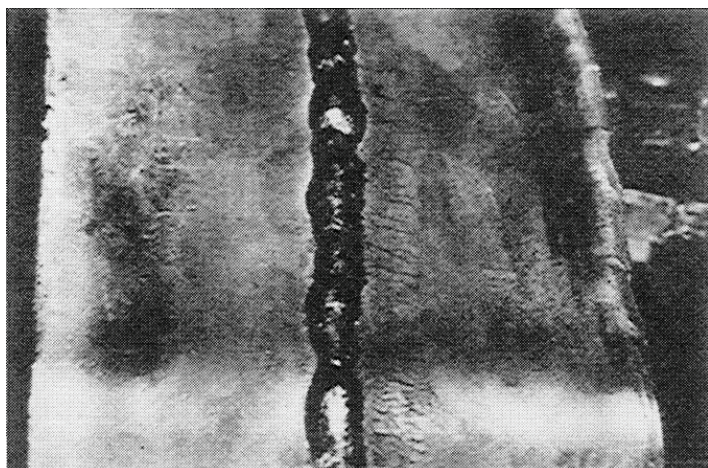

Photo courtesy Special Metals.

- Remove all solvent by wiping with clean, dry cloth;
- Check to assure complete cleaning. A residue on the drying cloth can indicate incomplete cleaning. Where size allows, either the water break or atomised test (ASTM A380) are effective checks.

If alkaline cleaners containing sodium carbonate are used, the cleaners themselves must be removed prior to welding by spraying or scrubbing with hot water. Selecting the solvent cleaner involves considerations beyond just the ability to remove oil and grease. Two precautions follow.

Chlorinated solvents

Many commercial solvents contain chlorides and are effective in cleaning machined parts and crevice-free components. While chlorinated solvents are acceptable for use on nickel alloy, they can present a corrosion problem to stainless steel alloys. Fabricators often use a non-chlorinated solvent for both stainless and nickel alloys to avoid the risk of using a chlorinated solvent on stainless steel.

Solvent health hazards

The term health hazard has been defined as including carcinogens, toxic agents, irritants, corrosives, sensitisers, and any agent that damages the lungs, skin, eyes, or mucous membranes. Each organisation should assure that the solvents used are not harmful to personnel or equipment. In addition to the toxic effect, consideration must be given to the venting of explosive fumes, safe disposal of spent solutions, and other related handling practices. Knowledge of, and compliance with federal, state, and local regulations is a necessity.

Solvents used for pre-weld cleaning include, but are not limited to the following:

- Non-chlorinated: toluene, methyl-ethyl-ketone and acetone;
- Chlorinated solvent: 1-1-1 trichloroethane.

All of the aforementioned solvents must be handled in compliance with the regulator requirements and the manufacturer's instructions.

Fixtures and positioners

Fixtures are usually designed for each particular assembly and hold the parts together throughout the welding

operation. When fixtures are attached to positioners, there is a further advantage in that welding can be done in the most convenient position. Some advantages of using fixtures are summarised as follows:

- Better joint match-up;
- Less tacking and welding time;
- Minimised distortion;
- Accurate assembly.

It is essential that the mating pieces be carefully aligned and matched for good quality welding. When one member is considerably thicker than the other, for example, a tank head that is thicker than the shell, the head-side should be machined to a taper of 3:1 or more to reduce stress concentrations. Joints with varying root opening require special adjustment by the welder to avoid burn-through or lack of penetration. When the volume of identical parts is large, use of fixtures is more easily justified

Backing materials

A backing material should be used in welding sheet or plate, unless both sides of the joint can be welded. Without a backing, the back side may have erratic penetration with crevices, voids and excessive oxidation. Such defects reduce weld strength and can initiate accelerated corrosion. Copper, with its high thermal conductivity, is the material most often used for backing bars. Typical backing bar designs for use with and without a backing gas are shown in *Figure 4*. During welding, the copper bar chills the weld to solid metal without melting the copper. The arc should not be misdirected to the extent that copper is melted and incorporated into the alloy weld or weld cracking can result. It is good practice to pickle after welding to remove traces of copper from the surface, particularly if solution annealing is to follow welding.

Argon backing gas provides excellent protection to the back side of gas tungsten arc welds (GTAW). It helps control penetration and maintain a bright, clean surface.

While nitrogen has been used as a backing gas for stainless steels and chromium-bearing nickel, Group II alloys, it should never be used for Group I or III, non-chromium-containing alloys. Nitrogen might also cause weld metal porosity in welds made with the GTAW process which have inadequate filler metal.

When copper backing bar or an inert gas backing purge is impractical, there are commercially available tapes, pastes, and ceramic backing products that can be utilised. These offer some protection from burn-through but little protection from oxidation, so final cleaning by abrasive means or acid pickling is needed after welding when these backing materials are used.

Tack welding

Joints not held in fixtures must be tack-welded to maintain a uniform gap and alignment along the entire length. The tacks should be placed in a sequence to minimise the effect of shrinkage. In fitting two sheets, tack welds should be placed at each end and then the middle section as shown in *Figure 5 (A)*. *Figure 5 (B)* shows how the sheets close up when the tack welding progresses from one end.

Nickel alloys have a thermal expansion close to that of ordinary steel so distortion from welding is less than is experienced with stainless steel. Tack welds in nickel alloy fabrications are about the same number and size as those required for carbon steel.

The length of tack welds may be as short as 3 mm (0.125 in.), or a small spot of weld metal for thin material to over 25 mm (1 in.) long for heavy plate sections. More importantly, the shape of the tack should not cause a defect in the final weld. Heavy or high tacks or abrupt starts and stops should be contour-ground. Bead shape is easier to control with the

Figure 4 Typical backing bar designs for use with and without a backing gas

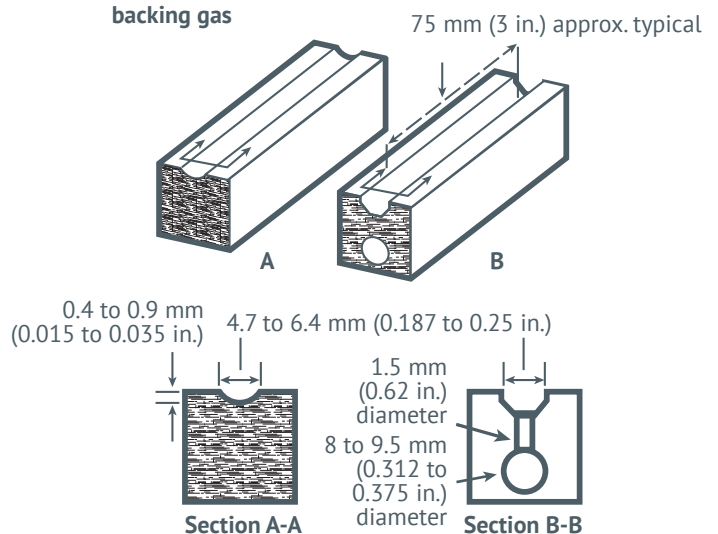

GTAW process, making it a good choice for tack welding. Before tack welds are incorporated into the final weld, they must be wire-brushed or ground to clean metal. They should be inspected for crater cracks and any cracks should be ground out.

Welding processes

This section provides information to assist in formulating nickel alloy welding procedures for the most commonly used fusion welding processes. The areas covered in earlier sections of this publication such as base metal properties, joint designs and preparation for welding are common to all welding processes and are not repeated.

Shielded metal arc welding (SMAW)

SMAW is a versatile process, widely used for welding nickel alloys when the shapes or quantities do not justify automatic welding. The welding is performed manually with the welder maintaining control over the arc length while directing the arc into the weld joint.

SMAW is frequently referred to as covered electrode or stick welding. The electrode is a solid wire covered by an extruded flux coating, although some manufacturers use a cored wire in lieu of the solid core wire.

The electrode coating supports the following functions:

- Initially at the arc start, the electrode core burns back faster to form a cup which in turn projects droplets and increases

Figure 5 Tack weld sequence to provide uniform root opening

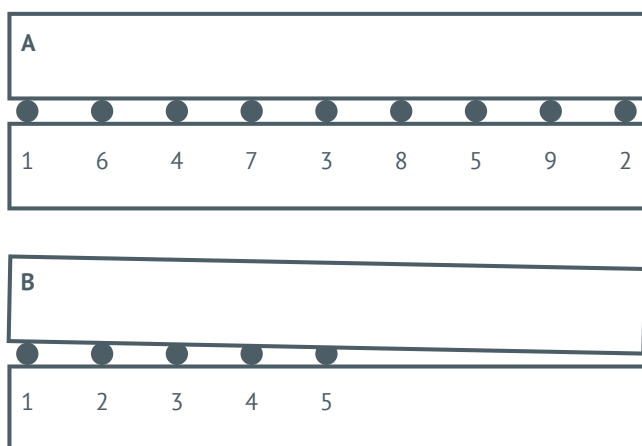

the pinch affect. This action supports the capability to weld out-of-position;

- It may provide alloy addition to the weld deposit. Usually the core wire is of similar composition to the deposited weld metal, but some electrode manufacturers make very large alloy additions through the coating and rely on complete mixing or alloying in the weld puddle. Because of this practice, it is not advisable to remove the flux in order to use the uncoated core wire for GTAW or any other process;
- The gaseous envelope from the flux decomposition excludes oxygen and nitrogen from the molten weld metal;
- The molten slag formed on top of the weld protects the weld metal from contamination by the atmosphere and helps to shape the bead.

Electrodes for SMAW are available for all solid solution nickel alloys, Groups I, II, and III but not for the precipitation hardening alloys, Group IV.

The arc zone in the SMAW process is shown in *Figure 6*.

Electrode types – Nickel alloy covered electrodes are classified according to chemical composition of undiluted weld metal. The matching composition filler metals and nickel alloys are shown in *Table 5*. Most nickel alloy electrodes are designed to operate on direct current, electrode positive, although some can operate on alternating current.

Figure 6 The arc zone in the SMAW process

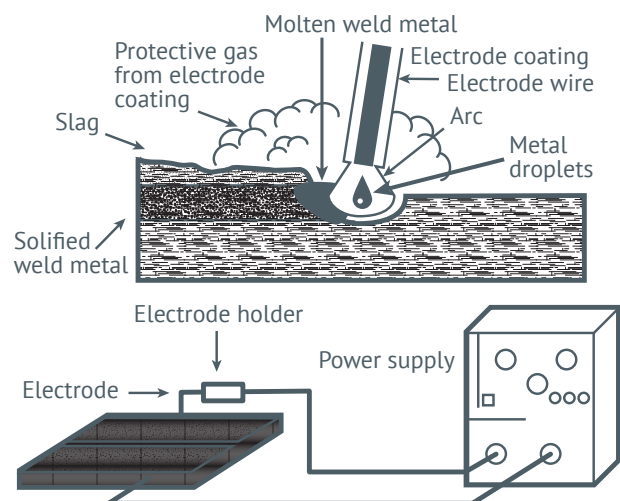

The type of coating is not identified in nickel alloy electrodes as it is for carbon and stainless steel electrodes. As with covered electrodes of other alloys, the flux formula is the proprietary secret of its manufacturer. Nickel alloy electrode coatings are best described as lime-titania type coatings; they cannot be classified as either lime or titania types because both compounds are used.

Electrode storage – Nickel alloy electrodes are normally furnished in packages suitable for long storage. After the package is opened, the electrodes should be stored in heated cabinets at the temperature recommended by the manufacturer. If the electrodes have been over-exposed to moisture, they should be reconditioned by a higher temperature bake using the manufacturer's suggested time and temperature. It is preferable to obtain the manufacturer's

specific recommendations, since the temperature often varies with the particular coating, but lacking this information, commonly used temperatures are as follows:

- Storage of opened electrodes: 110 °C (225 °F);
- Recondition bake: 260-315 °C (500-600 °F).

The nickel-molybdenum Group III coating formulation is a low hydrogen type and moisture pickup must be closely controlled. If the electrodes are exposed to moisture pick-up, they can be reconditioned by heating to 315-370 °C (600-700 °F) for two to three hours.

Moisture in the coating can cause hydrogen gas generation in the weld, leading to weld porosity. The porosity may be within the weld metal or may reach the surface just as the metal solidifies, forming visible surface pores. The porosity can

Table 5 Matching composition filler metals for nickel alloys

Base metal		Bare electrode and rod		Shielded metal arc electrode		Flux-cored electrode	
Alloy	UNS	AWS A5.11	UNS	AWS A5.14	UNS	AWS A5.34	UNS
200	N02200	ERNi-1	N02061	ENi-1	W82141		
201	N02201	ERNi-1	N02061	ENi-1	W82141		
400	N04400	ERNiCu-7	N04060	ENiCu-7	W84190		
R-405	N04405	Note 1		ENiCu-7	W84190		
825	N08825	ERNiCrMo-3	N06625	ENiCrMo-3	W86112	ENiCrMo3Tx-y	W86625
G-3	N06985	ERNiCrMo-9	N06985	ENiCrMo-9	W86985		
G-30	N06030	ERNiCrMo-11	N06030	ENiCrMo-11	W86030		
33	R20033	AWS A5.9 ER33-31	R20033				
600	N06600	ERNiCr-3	N06082	ENiCrFe-3	W86182	ENiCr3Tx-y	W86082
690	N06690	ERNiCrFe-7A	N06054	ENiCrFe-7	W86152		
625	N06625	ERNiCrMo-3	N06625	ENiCrMo-3	W86112		
C-22/622	N06022	ERNiCrMo-10	N06022	ENiCrMo-10	W86022	ENiCrMo10Tx-y	W86022
C-4	N06455	ERNiCrMo-7	N06455	ENiCrMo-7	W86455		
C-276	N10276	ERNiCrMo-4	N10276	ENiCrMo-4	W80276	ENiCrMo4Tx-y	W80276
59	N06059	ERNiCrMo-13	N06059	ENiCrMo-13	W86059		
686	N06686	ERNiCrMo-14	N06686	ENiCrMo-14	W86686		
2000	N06200	ERNiCrMo-17	N06200	ENiCrMo-17	W86200		
B-2	N05500	ERNiMo-7	N10665	ENiMo-7	W80665		
B-3	N10675	ERNiMo-10	N10675	ENiMo-10	W80675		
B-4	N10629	ERNiMo-11	N10629				

Notes: 1) SMAW is the preferred welding process

2) Group IV – Precipitation hardening alloys. Contact the base metal producers for filler metal recommendations

occur in butt welds when the moisture content of the coating is high, but more often, it occurs in fillet welds.

Moisture in the weld is not the only cause of weld metal porosity. Welding on painted, greasy, or oily surfaces may lead to porosity of the wormhole type.

Welding current – The recommended current ranges for electrodes is usually printed on the package. The current ranges may vary significantly from one alloy family to another. The electrical resistance of Group II core wires is much higher than Group I core wires so the recommended currents for Group II are substantially lower. Excessive current overheats the electrode coating which, in turn, causes a loss of arc force and difficulty in directing the arc near the end of the electrode.

Electrode handling – *Arc starting, stopping and weld bead contour* – The same techniques for arc starting and stopping used for low hydrogen carbon steel electrodes, such as type E7018, are applicable to nickel alloy welding.

Some guidelines follow:

- Strike the arc at some point in the joint so that the initial metal is remelted. An arc strike away from the weld may have cracks and unless removed, may result in lower corrosion resistance in that area;
- Do not abruptly extinguish the arc, leaving a large weld crater. A depression will form as the metal solidifies, often with a slag-filled pipe or cracks in the center of the crater depression. One acceptable technique is to hold the arc over the weld pool for a few moments and then move quickly back, lifting the arc from the completed weld. Another technique is to extinguish the arc against one of the joint side walls after filling the crater;
- The preferred weld bead contour is one that is flat or slightly convex in order to minimise the chance of center line cracking. Center line cracking sometimes occurs in fillet welds resulting from a concave bead contour.

Weld puddle control – It is necessary to maintain a short arc length for control of the weld puddle. In downhand welding, the electrode is positioned ahead of the puddle and at an incline of 20 or more degrees from the vertical (a drag angle). This is also described as backhand welding. The angle improves control of the molten flux and eliminates slag entrapment.

Out-of-position welding – Out of position welding should be done with a 3.2 mm (0.125 in.) or smaller diameter electrode using a shorter arc and lower current than for downhand welding. In vertical welding, a range of electrode angles is often used varying from 20 degrees drag (backhand) to 20 degrees push (forehand) depending on welder preference.

Nickel alloy weld metal does not flow or spread like most other metals and requires placing it to the desired spot in the joint. For proper bead placement, some weave or manipulation is needed. The amount of weave depends on such factors as joint design, welding position, and the type of electrode. With a little practice, welders soon learn the amount of weave needed to obtain the correct bead contour for various joint conditions. The acceptable width of weave is limited to a dimension no wider than three times the electrode core diameter.

Weld spatter – Under correct welding conditions, there should not be excessive spatter. When high spatter does occur, it may be caused by one of the following factors: excessive arc length, excessive amperage, incorrect polarity, or excessive moisture in the electrode coating. All of these factors are under the control of welding personnel and can be readily corrected. Magnetic arc blow can also cause excessive spatter. The corrective measures are the same as those used for other metals such as ordinary steel.

Weld slag removal – The slag on shielded metal arc welds or any flux welding process can usually be removed with hand tools or wire brushing. In multi-pass welding it is essential to remove all slag before depositing subsequent passes. It is not possible to burn-out deposited weld slag due to the shallow penetration of nickel alloy welds.

Gas tungsten arc welding (GTAW)

The gas tungsten arc weld (GTAW) process or tungsten inert gas process (TIG), as it is frequently called, is widely used and is well-suited for welding nickel alloys. It frequently is the only process used for welding precipitation hardening, Group IV alloys. An inert gas (usually argon) is used to protect the molten weld metal and the tungsten electrode from the air. Filler metal in the form of bare wire is added as needed, either by manual or automatic feeding into the arc. The process is illustrated in *Figure 7*. GTAW can be used to weld

material as thin as 0.05 mm (0.002 in.). Usually, faster welding processes are used for material thicknesses over 3.2 mm (0.125 in.).

Some of the advantages of the GTAW process for welding nickel alloys follow.

- No slag to remove – minimises post-weld cleanup;
- All position welding capability – particularly useful for pipe welding;
- No weld spatter;
- No alloy loss during welding;
- Good as-welded surface – minimal finishing required.

GTAW equipment – *Power* – Direct current, electrode negative, (DCEN), (straight polarity) current is standard. Pulsed power welding is another option. With pulsed welding, there is a pulsating high rate of current rise and decay. This current mode is well-suited to welding thin materials and joints which have poor fit-up. Pulsed-current is also useful in making the root pass of pipe joints. A high-frequency or

capacitor discharge starting feature is often included in the power source. This starting feature is also available in a separate “arc starter” control for use with conventional constant current power sources. This allows an arc to be initiated without a scratch start, a procedure that risks contamination of the tungsten electrode.

Some power sources provide a “lift start” feature that allows the electrode to be positioned on the work before applying power. The arc is established when the torch is lifted from the work. The power source controls the current during the lift start and practically eliminates the risk of electrode contamination. The advantage of this method over high frequency starting is that it eliminates possible interference to nearby electronic equipment such as telephones, radios, and computers.

Current controls – In addition to the current controls at the power source, it is often useful to have a foot pedal or torch-mounted hand current control. This control allows the welder to increase or decrease current during welding to adjust to conditions such as poor fit-up. A further advantage to this type of control is that the welder can slowly reduce the current (and the weld pool) at arc stops to eliminate crater cracks.

Cooling – Torches are either air or water cooled. The air-cooled variety is limited to lower currents while the water-cooled units are needed for use at higher currents.

Electrodes – The 2% thoriated tungsten electrodes are most often used because of their excellent emissive qualities, although other tungsten electrode types are acceptable. Opinions differ regarding electrode size for various amperages. Some favour using a different diameter for a number of narrow current ranges while others use a size such as 2.4 mm (0.09 in.) for a much wider current range. Also, the electrode end preparation preferences vary. One commonly used configuration is a 20° to 25° taper with the tip blunted to a 2.5 mm (0.10 in.) diameter. Portable tungsten grinders are available that grind the electrodes to precise angles and have the further advantage of capturing the grinding dust.

Nozzles – Nozzle or gas cups come in a wide variety of shapes and sizes and it is often best to match the nozzle to the weld joint or application. Larger cup diameters provide

Figure 7 The gas tungsten arc weld (GTAW)

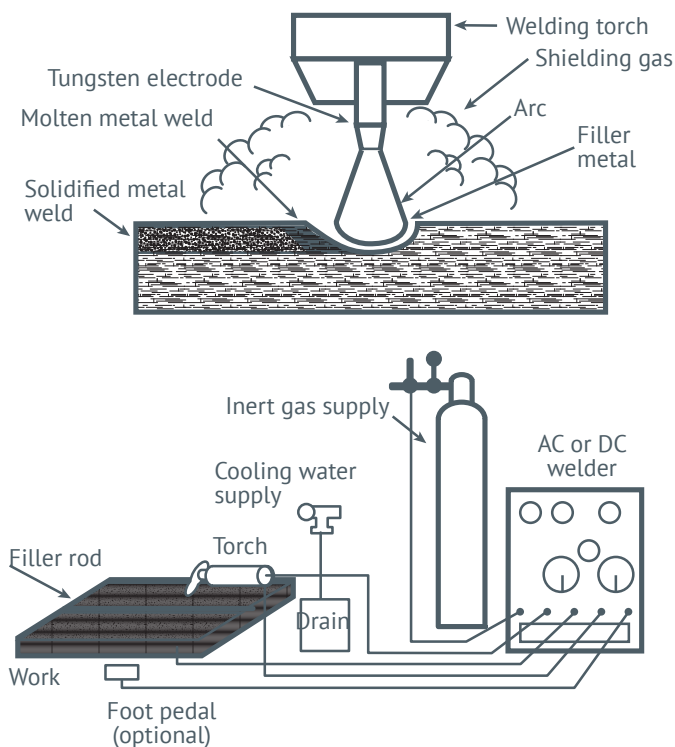

better shielding gas protection to the weld while smaller nozzles allow better visibility. An alternate is the gas lens which creates a laminar flow by using special screens inside the nozzle. The flow of inert gas is projected a considerable distance beyond the end of the nozzle, giving both better gas protection and good visibility.

System leaks – With any welding process using inert gas, it is important that all gas lines and connections be checked to ensure freedom from leaks in the system. If a leak is present, for example, in a gas line, air will aspirate into the inert gas stream rather than the internal gas escaping, as might be expected.

Shielding gases – Pure argon, helium, or mixtures of the two are used for shielding gas in welding nickel alloys. The oxygen-bearing argon mixtures used in GMAW welding should not be used in GTAW welding. Nitrogen additions are not recommended because of rapid deterioration of the tungsten electrode and also because they introduce the possibility of weld metal porosity in the non-chromium-bearing nickel alloys. In manual welding, argon is the preferred shielding gas. It provides good penetration at lower flow rates than helium and less chance of melt-through. Helium produces a higher heat input and deeper penetrating arc which may be an advantage in some automatic welding applications. Argon-helium mixtures may improve the bead contour and wettability. Hydrogen additions (up to 5%) may be added to argon for a hotter arc and more uniform bead surface in single pass automated welds.

Filler metals – The correct filler metals for GTAW welding of nickel alloys are shown in *Table 5*. Straight lengths are normally used for manual welding and spool or coil wire is used for automatic welding. Conventional quality control practices to assure clean wire and avoidance of material mix-up are essential. Bare wire for GTAW should be wiped clean before using and stored in a covered area.

Operator guidelines

Arc initiation – Arc initiation is made easier by devices such as high frequency, capacitor or lift start features (described earlier), or pilot arcs. In the absence of these devices, a scratch start is used which risks contaminating the electrode and the metal being welded. Where practical, starting tabs adjacent to the weld joint are useful in eliminating damage to the base metal.

Arc stopping – Care should be taken when extinguishing the arc to decrease the size of the weld pool, otherwise crater cracking is likely as the weld solidifies. In the absence of a foot pedal or hand current control described earlier, or a power source current decay system, decrease the arc pool by increasing the travel speed before lifting the electrode from the joint. Good arc-stopping practice is particularly important in the root pass of welds that are welded from only one side. If cracks occur in this situation, they may extend completely through the root, presenting a difficult repair. After the arc is broken, hold the torch over the crater for several seconds to allow the weld to cool under protection of the argon atmosphere.

Arc shielding – Nickel alloys are easy to weld with the GTAW process. The alloys are relatively insensitive to marginal shielding compared to reactive metals such as titanium or zirconium. It is good practice, however, to provide ample shielding protection to both the weld puddle and backside. It is also a good idea to keep the filler metal within the inert gas envelope during welding.

Filler metal addition – If the process has a potential short-coming, it is that the weld may look good but have an inadequate filler metal addition. In some weld joints, inadequate filler can result in a concave bead that has a tendency for centerline cracking. Adequate filler metal addition produces a slightly convex weld bead. Another result of inadequate filler metal may be porosity in the weld, particularly in the non-chromium bearing nickel alloys.

Nickel alloy filler metals – Nickel alloy filler metals often contain elements that are not in the base metal to control porosity or improve resistance to cracking. Welds of the desired composition are possible only when ample filler metal additions are made. It is difficult to define just how much is ample and to measure it. Experience suggests that at least 50% of the weld metal should be from filler metal addition. With adequate amounts of filler metal in the joint, it then becomes important that filler metal mixing takes place before the weld solidifies, otherwise segregated spots of melted base metal and melted filler metal may exist. Uneven melting of filler metal along with fast solidification rates can cause this type of segregation.

Gas metal arc welding (GMAW)

With the GMAW process, an arc is established between a consumable, bare wire electrode and the work piece. The arc and the deposited weld metal are protected from the atmosphere by a gas shield, comprised mainly of the inert gases, argon and/or helium. Small amounts of carbon dioxide may be used for better wetting, arc action and bead control. The process is referred to as MIG when an inert shielded gas is used and MAG when an active gas is used.

The advantages of GMAW over GTAW and SMAW are summarised as follows:

- Faster welding speeds;
- No slag, minimising post-weld cleanup;
- Ease of automation;
- Good transfer of elements across the arc.

The basic components of the GMAW process are shown in *Figure 8*.

Figure 8 The basic components of the gas metal arc weld (GMAW) process

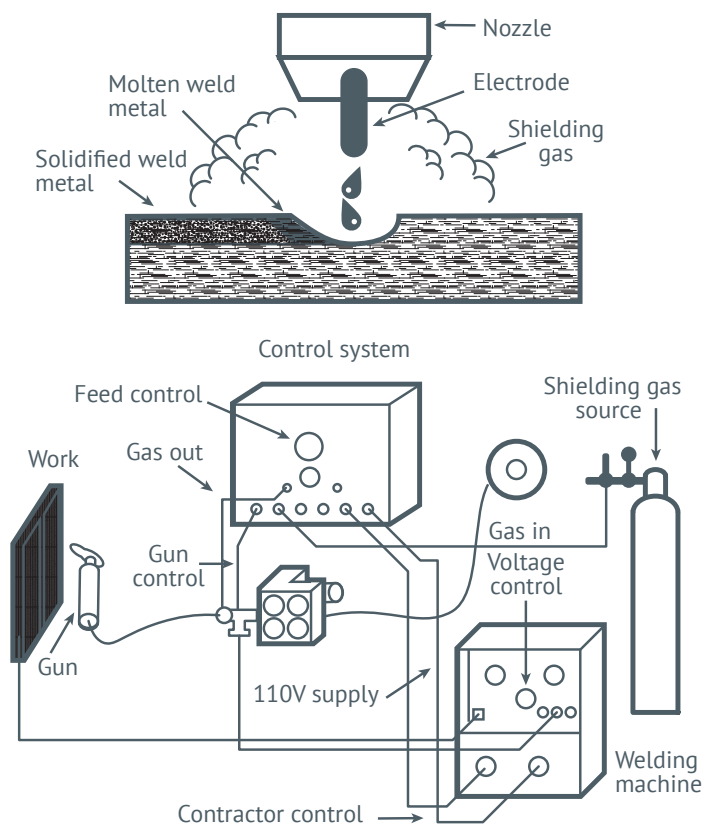

GMAW arc types – The type of metal transfer in GMAW has a profound influence on the process characteristics to the extent that it is often misleading to make general statements about GMAW without indicating the arc transfer mode. The three modes in most frequent use in welding nickel alloys are spray arc, short circuiting arc and pulsed arc.

The spray arc process is characterised by high deposit rates and high heat input. The arc is quite stable, but welding is generally limited to the flat position and base metal thickness over about 6.5 mm (0.25 in.).

The short-circuiting arc provides a low heat input transfer mode and therefore minimises distortion in welding thinner material. It is most useful for single-pass welding, but has limitations when used on multiple pass, thick joints where the process is somewhat prone to lack of fusion defects. In addition, the weld beads tend to be rather convex and this may necessitate grinding beads to assure full penetration to the side wall.

The pulsed arc mode of gas metal arc welding (either fixed frequency pulse or computer controlled pulse mode) is an excellent compromise between spray arc and short-circuiting arc modes in the general fabrication of nickel alloys. It is less susceptible to cold laps when compared to short circuiting and less prone to undercut compared to the spray arc mode. Comparisons of GMAW arc modes are shown in *Table 6*.

GMAW equipment – The same power sources, wire feed mechanisms, and torches used for welding ordinary steels are used for nickel alloys. Plastic liners in the wire feed conduit are helpful in reducing drag. The GMAW process has more weld parameter controls than the GTAW and SMAW processes. The GMAW process controls amperage, voltage, current slope wire feed, pulse rate, and transfer mode; consequently, the process is more complex. The synergic pulsed arc power source makes operation simpler by providing only one or two control dials for the operator. The remaining parameters are adjusted automatically or are programmed into the power source. The synergic mode power source has many advantages over the original fixed frequency pulse mode and is largely replacing fixed frequency units.

The welding current used in most power sources is the direct current electrode positive (DCEP) – reversed polarity.

This current gives deeper penetration and a more stable arc than direct current electrode negative (DCEN) – straight polarity. The DCEN approach finds its best use in applications requiring shallow penetration such as overlay welding.

Consumables – Some of the most popular shielding gases used in GMAW are shown in *Table 6*. Argon is the shielding gas that is usually used for spray arc GMAW. Short circuiting and pulsed arc GMAW use a variety of shielding gases. A mixture of He + Ar + CO₂ is a popular mixture in North America. In Europe, helium is quite expensive so a mixture of Ar + He + CO₂ is often the mixture of choice. Whatever the combination, the shielding gas should contain at least 97.5% inert gases (argon, helium, or a mixture of the two).

Carbon dioxide additions (up to 2.5%) can improve arc stability and are often used for out of position welding. However, the presence of carbon dioxide causes oxide formation on the weld surface that needs removal prior to the next weld pass in multipass welds.

The preferred filler metals in GMAW nickel alloys are shown in *Table 5*. The most widely used diameters are 0.9 mm, 1.2 mm, and 1.6 mm (0.035 in., 0.045 in., and 0.062 in.) but other diameters are available.

Flux cored arc welding (FCAW)

The flux cored arc welding process uses a power source similar to that used for the GMAW process with a tubular,

flux-containing continuous electrode. Shielding is obtained from the flux, with or without additional shielding from an externally supplied gas. Most of the nickel alloy electrodes use a shielding gas of CO₂ or a Ar-CO₂ mixture. The FCAW process offers increased productivity over the GMAW or SMAW processes and many products have all-position capability.

AWS A5.34/A5.34M, Specification for Nickel-Alloy Electrodes for Flux Cored Arc Welding, was issued in 2007. A listing of FCAW electrodes in AWS A5.34 is shown in *Table 5*. Currently the specification includes only chromium-bearing solid solution alloys, Group II, but there are commercially available other nickel alloy products such as a nickel-copper electrode. The electrode manufacturer should be consulted for shielding gas and amperage range recommendations.

Submerged arc welding (SAW)

The submerged arc welding process is used for welding thickness of 6.5 mm (0.25 in.) and thicker and for overlay welding. The process has the advantage of up to 50% higher deposition rates compared to the GMAW process and the ability to produce a smooth as-welded surface which is an advantage in overlay welding. It is also somewhat more operator friendly in that the operator is not exposed to the arc and there are generally lower fumes compared to other welding processes.

Table 6 Comparison of GMAW arc modes for nickel alloys

Material/weld variable	Spray arc mode	Short circuiting mode	Pulsed arc mode
Typical thickness welded	3 mm (0.125 in.) min., 6 mm (0.25 in.) and thicker is normal	1.6 mm (0.062 in.) and up	1.6 mm (0.062 in.) and up
Welding positions	flat	all	all
Relative deposition rate	highest	lowest	intermediate
Typical wire diameter	1.6 mm (0.062 in.) 1.2 mm (0.045 in.)	0.8 or 0.9mm (0.030 or 0.035 in.)	0.9 or 1.2mm (0.035 or 0.045 in.)
Typical welding current	250-350 amps	70-130 amps	60 to 150 amps
Shielding gas ⁽¹⁾	Argon	He + Ar + CO ₂ or Ar + He + CO ₂ or Ar + He	Ar + He or He + Ar or Ar + He + CO ₂

⁽¹⁾ Other gas mixtures are used; however, the shielding gas normally contains at least 97.5% inert gas, i.e., argon, helium, or a mixture of the two

There are commercially available SAW fluxes for all the Group I and II alloys, however, there is not an AWS specification for any of the SAW fluxes. During welding the flux becomes molten and protects the weld metal from the atmosphere, provides for a stable arc and may add alloying elements to the weld puddle. The fluxes are commonly fused or bonded fluxes. Most nickel alloy fluxes are a mechanical mixture of ingredients bonded together, but not fused. With this method, it is possible to add alloying elements to the flux.

The fluxes will absorb moisture if exposed to air so open containers should be stored in a dry area. If re-baking is required, the manufacturers recommendations should be followed. Typically, a flux is reclaimed by baking in a vented oven at 315 to 480 °C (600 to 900 °F) for two hours. Unfused flux is usually reclaimed although continual recycling of the flux can alter the balance of fine/coarse particles.

The wire-flux combination is critical and consumable manufacturers should be consulted for a wire-flux recommendation. The wire-flux combination should not be changed without a requalification. The filler metals for SAW are the same as used for GMAW as shown in *Table 5* with diameters ranging from 0.9 to 2.4 mm (0.045 to 0.094 in.). While larger diameter wires are used in welding ordinary steel, the 1.6 mm (0.062 in.) diameter is generally preferred in nickel alloys to avoid the potential of weld solidification cracking. Another concern in SAW nickel alloys is a possible silicon pick up that could contribute to hot cracking so fluxes giving a low silicon pick up should be used.

Nickel alloy submerged arc welding is with direct current, either electrode positive (DCEP – reverse polarity) or electrode negative (DCEN – straight polarity). Electrode positive, reverse polarity is usually used for butt welds because it produces a deeper penetration and flatter weld bead. For overlay welding electrode negative, straight polarity has the advantage of somewhat higher deposit rate and lower weld penetration.

For weld overlays, there exists SAW with thin strip instead of wire, which is more efficient for weld overlaying large surface areas. An even more efficient process variation is called Electroslag Welding (ESW).

Other welding processes

Plasma arc, electron beam, and laser welding processes

are used in welding nickel alloys. The resistance welding processes; spot, seam, projection, and flush welding are readily adaptable to most nickel alloys, however they find limited use in welding for corrosion resistant services.

Brazing can be used to join nickel alloys to themselves or to a number of other alloys. Brazing is not usually used for severe corrosion environments such as the applications discussed herein.

Welding nickel alloy pipe

Piping systems are a very vital part of many industrial process plants. The fabrication and welding techniques for pipe are somewhat different from those used for tanks, pressure vessels, and similar equipment. One major difference is that in piping systems, the internal root is seldom accessible for backside welding so the root pass must be made correctly from the outside. Since pipe welding procedure and technique is such an extensive topic, it is only highlighted in this publication.

Types of pipe welding

The pipe size, equipment available, and welder skill or experience determine to a large extent the type of pipe weld and joint design that is best for a particular application. The particular nickel alloy is usually of secondary significance. In fact, there is a great deal of commonality in welding a range of alloys from carbon steel to stainless steel to the nickel alloys. A discussion on some of the most common piping joints follows.

Instrument piping

Instrument piping, usually about 13 mm (0.5 in.) and less in diameter, is often joined by socket welds or it may be mechanically joined. Elements of a good socket welding procedure include GTAW root and cap pass and a gap of 1.6 mm (0.062 in.) between the end of the pipe and the socket face. Use of an internal purge prevents oxide formation on the pipe ID which may be of significance in some piping systems.

Automatic welding

There are a number of commercially available GTAW orbital pipe welding units that can be used for welding nickel alloys.

Orbital welding heads typically span a range of tube sizes and routinely weld tubes down to 6.4 mm (0.25 in.) diameter and up 152 mm (6.0 in.). Enclosed welding heads give added inert gas protection in making autogenous welds. Orbital tube welding power supplies control welding parameter that typically include welding current, primary and background amperages, travel speed (RPM), timers that control the amount of time at particular settings, pulse timers that determine the amount of weld bead overlap, delay of rotation at the start of the weld, and current downslope at the end of the weld.

The thinner wall chromium-bearing Group II alloys can readily be autogenously welded and filler metal added on heavier wall tubes to complete the weld after the root pass. The Group I alloys are more sensitive to porosity from gases such as oxygen, nitrogen and CO₂ in making autogenous welds. Therefore, the addition of filler metal or use of consumable inserts may be for Group I alloys or alternately extra care in shielding gas protection. Internal inert gas purging is discussed later and is an essential part of producing good quality automatic welds.

Manual welding

A large quantity of nickel alloy piping is manually welded. Manual welding may be the choice when automatic welding equipment is not available, the project does not merit the expenditure, or the pipe configuration or location where welding is done are better suited to manual welding.

In manual welding nickel alloys, as with steel piping over about 13 mm (0.5 in.), the three options are:

- The use of backing rings;
- Consumable inserts;
- Open root joints with hand-fed filler metal.

Backing rings are a very poor choice for nickel alloy process piping. If the SMAW process is used, slag may be trapped between the pipe ID and the backing ring creating a potential corrosion site. In addition, backing rings can reduce flow in the pipe and they become a site for crevice corrosion.

The remaining two procedures, the use of consumable inserts and the open root joint with hand-fed filler metal, are equally

good selections for the root pass manual welding of nickel alloys with the GTAW process. Both procedures produce high quality root welds in the hands of capable welders. The two types of joint designs in popular use are shown in *Figures 9 and 10*.

The standard consumable insert shapes are shown in *Figure 11* and are available in a number of nickel filler alloys to ANSI/AWS A5.30. Class 1; 3, and 5 are often used for nickel alloys. Classes 3 and 5 are often easier to fuse than the larger volume of Class 1. The consumable insert is placed into the joint and tacks are made between the insert and the pipe. The interior of the pipe must be purged to prevent oxidising

Figure 9 Typical joint design for pipe with consumable insert

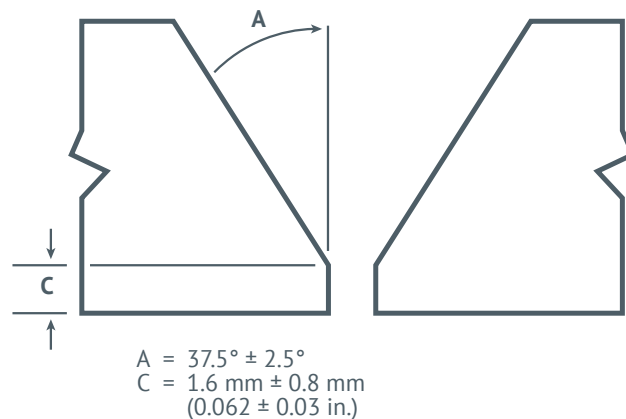
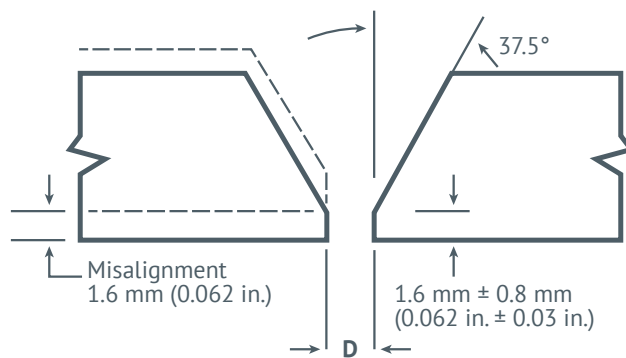

Figure 10 Typical joint design for pipe welded with open root joint and hand-fed filler metal



D < Diameter of filler metal for keyhole method
 D > Diameter of filler metal for continuous feeding method

the tacks. The rise of the molten pool indicates that the insert is completely fused. With experience, the welder observes this change and adjusts travel speed accordingly. When the pipe can be rotated, the root pass is completed without stopping. When the pipe is in a fixed position, welding is usually done in sectors, alternating from side to side.

In tacking joints without consumable inserts, or open root welds, as they are called, there is a strong tendency for the shrinking forces to pull the joint closed. To maintain the desired gap, it may be necessary to use spacers and to increase the size and number of tack welds. Spacers are usually short lengths of suitable diameter, clean filler wire. Any cracked or defective tack welds should be ground out. Both ends of the tacks on open root welds should be tapered to aid in fusing into the root weld.

The need to maintain a proper gap during root pass welding is two-fold. First, a consistent and uniform gap aids the welder in producing the optimum ID root contour. The other reason for a uniform root gap is the need to maintain the optimum root pass chemical composition.

Purging during pipe root welding

Figure 11 Standard consumable insert shapes, ANSI/AWS D10.11

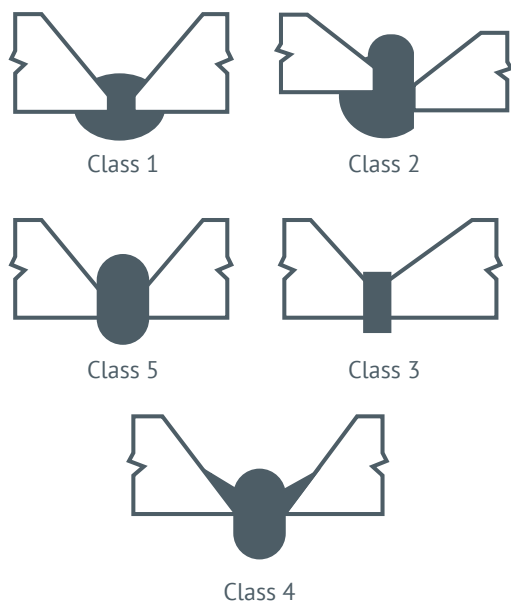

The pipe interior must be purged with an inert gas prior to and during the GTAW root pass as well as a couple of fill passes. Failure to use a purge can result in heavily oxidised ID root surface with substantially lower corrosion resistance. Purging is usually done with pure argon, but helium may also be used.

Purging is a two-step operation, the first being done prior to welding to displace air inside the pipe. To save time and purging gas, baffles on either side of the weld joint are often used to reduce the purge area.

Open root weld joints should be taped and dead air spaces vented prior to purging. The internal purge atmosphere should be essentially free of oxygen and moisture in order to obtain a root surface with little or no surface oxide. In practice, it is difficult to specify a single oxygen limit that can be consistently obtained with all piping configurations, joint fit up conditions and other variations. The maximum amount of oxygen should be in the order of 5000 ppm but every effort should be made to obtain a lower level. At about 5000 ppm oxygen, the root may be oxidised, but not to the degree that a "sugary" weld bead is obtained. Typical purging fixtures are shown in Figure 12.

Figure 12 Typical pipe purging fixtures

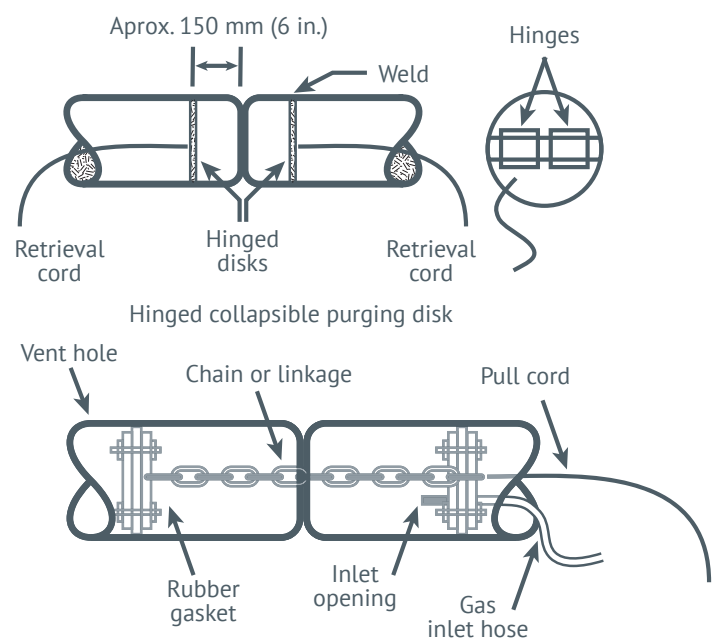

After the proper purity level has been reached, the purge flow rate is adjusted. When welding carbon steel and stainless steel, the common practice is to use a purge flow rate of about 5 L/min. (10 ft³/hr.) and a torch flow in the order of 16 L/min. (35 ft³/hr.). In welding nickel alloys with an open butt, Haynes International has found that there is less root oxidation with the rates reversed, that is, about 19 L/min. (40 ft.³/hr.) purge and 5 L/min. (10 ft.³/hr.) torch.

In either practice an internal pressure build-up must be avoided or a concave root will result. In extreme cases, a hole may occur completely through the root. The purge gas exit hole should be sufficiently large that it does not contribute to pressure build-up in the pipe. The tape on the outside of the joint is peeled back in advance of the weld arc. Near the end of the root pass, the purge flow rate should be reduced to a very low level to prevent a blow-back.

After the root pass, the internal purge should be maintained during the next two fill passes in order to minimise heat tint (oxidation) on the inside weld surface. This is especially important when it is impractical to pickle after welding.

For those needing more information on GTAW root pass pipe welding, there are a number of technical articles and specifications available. Two excellent sources are the American Welding Society publications listed in the general references to this publication. While they are written mainly for steel, most information is applicable to nickel alloys.

Post-fabrication cleaning

All too often, it is assumed that the fabrication, be it a tank, pressure vessel, or pipe assembly, is ready for service after the final weld is made and inspected. Post-fabrication cleaning may be as important as any of the fabrication steps discussed. The surface condition of the nickel alloy is equally important where the product must not be contaminated, as in a pharmaceutical, food, or nuclear plant; as well as where the alloy must resist an aggressive environment, as in a chemical or other process industry plant. Some guidelines on post-fabrication clean-up follow.

Surface contaminants – Examples of typical contaminants include grease, oil, crayon markers, paint, adhesive tape and other sticky deposits. Such contaminants can adversely affect product purity and in some environments, may foster crevice

corrosion. Typically, these contaminants can be removed by spraying or scrubbing with a detergent or solvent.

Embedded iron – During fabrication operations, iron particles can become embedded, then they corrode in moist air or when wetted, leaving tell-tale rust streaks. In addition to creating an unsightly condition, the iron particles might initiate local attack or, when used in process equipment, they might affect product purity.

Some tests to detect embedded iron follow and also see ASTM A380 and A967 for further details and other tests.

- Spray the surface with clean water and inspect for rust streaks after 24 hours;
- Immerse the surface in a 1% sodium chloride solution or use as a spray in enclosed spaces such as tanks. Inspect for rust spots after 12 to 24 hours;
- For small areas, use a ferroxyl test. The formation of blue spots indicates the presence of free iron.

The composition of one ferroxyl test solution is as follows:

Agar-agar	10g
Potassium ferricyanide	1g
Sodium chloride	1g
Water	1000ml

Apply as a warm solution and allow at least two hours before checking. The solution jells as it cools.

Free iron can be removed by an acid pickle treatment. First, the surface must be cleaned of any oil or grease, otherwise the acid is ineffective. An effective pickling solution for Group I alloys follows:

Hydrochloric acid	30ml
Ferric chloride	11g
Water	1000ml

For Group II chromium-bearing alloys, a nitric-hydrofluoric acid solution of 10-20% nitric acid and 2% hydrofluoric acid is quite effective.

When pickling is not practical, abrasive blasting, fine grit flapper wheels or disks can be used. With any blasting, care must be taken to assure that the abrasive is free from iron or other foreign material that could contaminate the surface.

Part II

For the materials engineer

This section is for the engineer who needs further information about the metallurgy and fabrication practices that are appropriate for wrought and cast nickel alloys. Refer to Part I for suggestions concerning good material storage practices. Additional information in this discussion, which was not included in Part I, may be useful for formulating Welding Procedure Specifications or Quality Control documents. Topics covered include the effect of welding on corrosion resistance, post-fabrication heat treatment, and guides for material procurement.

Table 7 shows the nominal composition of wrought nickel and nickel alloys. *Table 8* shows the nominal composition of cast nickel alloys.

General guidelines for nickel alloys

Guidelines that apply to all nickel alloys are discussed first. Since the general guidelines are not appropriate to all groups, specific headings indicate the appropriate considerations for Groups I, II, III, and IV alloys. These groups are shown in *Table 7*.

Preheat and interpass temperature – Preheat of nickel alloys is not required except to bring the metal in the area to be welded to room temperature or to a typical shop temperature to prevent moisture condensation. A maximum interpass temperature of 175 °C (350 °F) is widely used although one base metal producer is more conservative and recommends a maximum of 95 °C (200 °F).

Post-weld heat treatment – In most all instances, solid solution nickel alloys do not require a post-weld heat treatment for corrosion-resisting service. Precipitation-hardening alloys require heat treatment after welding to develop full strength. When heat treatment or stress relief is required for specific applications; for example, to anneal following cold forming, or for dimensional stability, the user

should consult the nickel alloy producer's literature or their technical specialists for specific recommendations.

Prior to any heat treatment, it is essential that all alloy surfaces be thoroughly cleaned of oil, grease, paint, or markings, and similar contaminants to avoid catastrophic corrosion during heat treatment. The method of heating and cooling and the amount of sulphur in the furnace atmosphere must be controlled or the alloys can be damaged.

Filler metal selection for corrosive environments – Nickel alloys are normally welded with matching or near matching composition filler metals as shown in *Table 5*. In sea water and some environments, nickel-copper (Group I) alloy welds made with matching composition filler metals may be anodic to the base metal and corrode preferentially by galvanic corrosion. This condition can be attributed largely to the fact that many "matching composition" filler metals are not of identical composition; some elements have been added or amounts adjusted for better weldability. Another factor to consider is that weld metal may also become anodic to the base metal as a result of segregation as it solidifies.

When experience demonstrates that matching composition welds corrode preferentially to the base metal, non-matching composition filler metals should be used that are both compatible metallurgically with the base metal and are cathodic to the base metal in the particular environment. Selection should be made by knowledgeable material specialist or by on-site evaluation tests.

It is important to remember that most welding codes specify that a change in filler metal, e.g., a change in F-No. per ASME Section IX, requires a separate welding procedure specification and welding procedure test.

Group I – Nickel and nickel-copper alloys

Welders soon discover that the welding characteristics of nickel and, to a lesser degree, nickel-copper alloys are somewhat different from the chromium-bearing nickel alloys or the austenitic stainless steels. Primary among the differences is the low viscosity or inability of the molten weld

metal to spread or flow in the joint; however, competent welders soon become accustomed to this and are able to produce quality welds. The materials engineer who is aware of this viscosity difference in advance is better prepared to cope with the false “materials problem” reports from uninitiated shop personnel.

Table 7 Nominal composition of significant elements of Group I – IV wrought nickel and nickel alloys⁽⁴⁾

Alloy	UNS	Ni ⁽¹⁾	C	Cr	Mo	Fe	Co	Cu	Al	Ti	Nb ⁽²⁾	W
Group I Nickel and nickel-copper solid solution alloys – Composition percent												
200	N02200	99.5	0.08			0.2		0.1				
201	N02201	99.5	0.01			0.2		0.1				
400	N04400	66.5	0.2			1.2		31.5				
R-405 ⁽⁵⁾	N04405	66.5	0.2			1.2		31.5				
Group II Chromium-bearing solid solution alloys – Composition percent												
825	N08825	42	0.03	21.5	3	30		2.25	0.1	0.9		
G-3	N06985	46	0.01	22.2	7	19.5	2.5	2				
G-30	N06030	42	0.01	29.7	5	15	2.5	1.8				
33	R20033	31.5	0.01	33	1	32		1				
600	N06600	76	0.08	15.5		8		0.2				
690	N06690	61.5	0.02	29		9						
625	N06625	61	0.05	21.5	9	2.5			0.2	0.2	3.6	
C-22/622	N06022	56	0.01	21.2	13.5	4	1					3
C-4	N06455	66	0.01	16	15	5.5	1					
C-276	N10276	58	0.01	15.5	16	5.5	1					3.7
59	N06059	60	0.01	23	15.7	0.7						
686	N06686	56	0.01	21	16	2.5			0.2	0.1		3.7
2000	N06200	57	0.01	23	16	1.5		1.5				
Group III Nickel-molybdenum alloys – Composition percent												
B-2	N10665	70.5	0.01		28							
B-3	N10675	63	0.005	2	30	2						1.5
B-4	N10629	66	0.01	1	28	4			0.3			
Group IV Precipitation-hardening alloys – Composition percent												
K-500	N05500	64	0.2			1		30	2.7	0.6		
725	N07725	57	0.1	20.	8	9			0.25	1.3	3.3	
625Plus®	N07716	60	0.1	21.5	8.2	5			0.2	1.3	3.3	
718	N07718	52.5	0.04	19	3	18			0.5	0.9	5.2	

⁽¹⁾ Includes small amount of cobalt if cobalt content is not specified

⁽²⁾ Includes tantalum also

⁽³⁾ 625Plus® is registered trademark of Carpenter Technology Corp.

⁽⁴⁾ Refer to ASTM specifications for complete composition

⁽⁵⁾ The difference between Alloy R-405 and Alloy 400 is a required sulphur range of 0.025-0.06% in Alloy R-405 and only a maximum sulphur of 0.024% in Alloy 400

Alloys 200 and 201 – Nickel 200 and 201 differ in the amount of carbon, 0.15% maximum in Nickel 200 and 0.02% maximum in 201. Prolonged exposure of Nickel 200 with a higher carbon content in the temperature range of 425-650 °C (800-1200 °F) precipitates graphite. For this reason, Nickel 201 is recommended for service in the 315-650 °C (600-1200 °F) temperature range. Nickel filler metal welds (ENi-1 and ERNi-1) are not subject to graphite precipitation due to a composition modification and are used for welding both Nickel 200 and 201.

Alloy 400 and R-405 – Alloy 400 is readily welded by all the common welding processes discussed in Part I. Alloy R-405 is a free-machining grade of alloy 400, containing 0.025-0.060% sulphur and is available as rods or bars. Parts made of alloy R-405 usually involve little or no welding, but when welding is required, it is good practice to make generous filler metal additions and to minimise the amount of base metal melted, thus reducing the amount of sulphur in the weld. Alloy R-405 welds made with the SMAW process are often less affected by sulphur from the base metal than welds made by GTAW or GMAW.

Salt and brine environments – The standard matching composition filler metals for welding alloy 400 are shown in *Table 5*. It is important to note, however, that in salt or brine environments, alloy 400 matching composition welds may become anodic to the base metal and suffer galvanic corrosion attack. To solve this problem in brine environments, nickel-chromium type electrodes are used such as ENiCrFe-2 and ENiCrMo-3. Welds made with these electrodes are

cathodic to the base metal and thus, resist galvanic corrosion.

Hydrofluoric acid service – Welded alloy 400 equipment used in hydrofluoric acid service should receive a post-weld stress relief to avoid stress corrosion cracking. The stress relief treatment is performed at 540-650 °C (1000-1200 °F) for one hour followed by slow cooling.

Group II – Chromium-bearing alloys

The nickel-chromium, nickel-iron-chromium, and nickel-chromium-molybdenum alloys may exhibit carbide precipitation in the weld heat-affected zone, a condition similar to that encountered in austenitic stainless steels. In most environments, however, the sensitisation of these nickel alloys is not sufficient to affect the corrosion resistance; as a result, solution annealing is seldom required. Two factors function to reduce sensitisation: very low carbon levels (as a result of recent improved melting practices), and the use of stabilising additions of titanium and columbium in many alloys.

A post-weld heat treatment to prevent stress corrosion cracking is recommended when alloy 600 is used in high-temperature, high-strength caustic-alkali service. The stress relief treatment is performed at a temperature of 900 °C (1650 °F) for one hour or at 790 °C (1450 °F) for four hours with a slow cool.

Group III – Nickel-molybdenum alloys

The materials engineer involved in fabrication of nickel-molybdenum alloy equipment should be aware of the

Table 8 Nominal composition of cast corrosion resistant nickel alloys ASTM A494

Ni & NiCu Group I - Composition percent						
Alloy	UNS	Ni	Cr	Mo	Other	Wrought equivalent
CZ100 M-35-1	N02100 N24135	97 65			0.75 Cu, 1 Si 29.5 Cu, 2 Fe, 0.3 Nb	Nickel 200 Alloy 400
NiCrFe & NiCrMo Group II - Composition percent						
CW6MC CY40 CW2M CX2MW	N26625 N06040 N26455 N26022	60 75 65 56	21.5 15 16 21	9.0 16 13.5	Fe, 3.8 Nb 7 Fe 1 Fe, 0.5 W 4 Fe, 3 W	Alloy 625 Alloy 600 Alloy C Alloy C-22
NiMo Group III - Composition percent						
N7M N3M	J30007 J30003	66 66	0.5 0.5	31.5 31.5	1.5 Fe 1.5 Fe	Alloy B-2 Alloy B-3

background behind the three grades; alloys B-2, B-3, and B-4, along with the precautions required in post-fabrication heat treatment. The welder will use matching filler metals for all three alloys and should detect no difference between the three alloys. For this reason, the subject was not discussed in *Part I, For the welder*.

Alloy B-2 has been the standard nickel-molybdenum alloy for a number of years, having replaced the older alloy B. Alloy B had a shortcoming in that it required a solution anneal at a temperature of 1175 °C (2150 °F) after welding to eliminate carbide precipitates in the weld heat-affected zone and to restore corrosion resistance. A modification of the alloy composition resulted in the formulation of alloy B-2 which demonstrates acceptable corrosion resistance in the as-welded condition. This development made possible the construction of fabrications too large to be solution annealed.

Work with alloy B-2, however, revealed a problem: it experiences a phase transformation during brief exposure to temperatures in the range of 595-815 °C (1100-1500 °F). Such exposure can result in cracking during base metal manufacturing operations or annealing by fabricators after cold working. Recent alloy modifications by two different metal producers have overcome the 595-815 °C (1100-1500 °F) low ductility problem and associated cracking of alloy B-2. The result of their work is the introduction of the two alloys: B-3 and B-4.

This is a very brief treatment of the nickel-molybdenum alloys. Fabricators new to these alloys should contact the producers before undertaking complex fabrications.

Group IV – Precipitation-hardening nickel alloys

The precipitation-hardening nickel alloys have limited use in corrosion-resisting service so this publication covers only the most important guidelines. Consult with the alloy manufacturers for more detailed information.

The precipitation-hardening nickel alloys are used in applications requiring corrosion resistance and a need for greater mechanical strength or higher hardness than is obtainable with the corresponding solid solution alloys. The precipitation-hardening or age hardening, as it is often called, is accomplished by the addition of increased amounts of titanium and aluminum along with special heat treatments.

The heat-treating temperatures vary from 600-760 °C (1100-1400 °F) depending upon the alloy and specific properties desired. The hardenable alloys in the soft or solution-annealed condition have about the same strength as the comparable solid solution alloy.

Of the hardenable alloys covered in this publication, i.e., alloys K-500, 725, 625 PLUS® and 718, only alloy 718 has an AWS matching composition filler metal (ANSI/AWS A5.14 ERNiFeCr-2) that can be strengthened by heat treatment. In practice, this has seldom presented a problem since most applications do not involve welds that must develop the same strength as the base metals. An example is a fillet weld used for attachments and where the fillet weld size can be increased. When full weld metal strength is not required, the practice is to use a filler metal of the comparable solid solution alloy as shown in *Table 9* that follows.

Dissimilar-metal welds (DMW)

In dissimilar-metal welding, the properties of three metals must be considered; the two metals being joined and the filler metal used to join them. For example, if one of the metals being joined is welded using preheat when welding to itself, preheat should be used in making a DMW. Another variable might be the need for a post-weld heat treatment. On occasion, there may be a conflict in that the optimum control for one metal is undesirable for the other. In this case, a compromise is needed. This is one reason the development of a DMW procedure often requires more study than for a conventional similar-metal welding procedure. (ref. NI 14018)

Table 10-A, which follows, presents the filler metal alloy identifications which are referenced in *Tables 10-B* and *10-C*. *Tables 10-B* and *10-C* list the dissimilar metal weld combinations and the suggested filler metals by identification (shown in *Table 10-A*). These DMWs represent the nickel alloys

Table 9 Matching filler metals of the comparable solid solution alloys		
Alloy	Bare electrodes ANSI/AWS A5.14	Coated electrodes ANSI/AWS A5.11
K-500	ERNiCu-7	ENiCu-7
725 & 625 PLUS®	ERNiCrMo-3	ENiCrMo-3
718	ERNiCrMo-3	ENiCrMo-3

covered in this document welded to each other and to some of the common steels.

The fillers indicated are those that are capable of making metallurgically sound welds using proper welding procedures with the SMAW, GMAW, and GTAW processes. Welding procedures can also be developed for other welding processes such as SAW and FCAW using comparable filler metals shown in *Table 10-A*. In making DMWs, it is desirable to keep the base metal dilution to a minimum and to keep the amount of base metal melted into the weld uniform along the length of the weld.

Base metal dilution is more easily controlled with the SMAW process and to almost the same degree with the GMAW process. In the manual GTAW process, the amount of filler metal added (and conversely the amount of base metal melted) may vary considerably depending on welder technique. For this reason, welder training and qualification is particularly important for DMWs made with the GTAW process.

Table 10-A Filler metal alloy identification for bare and covered electrodes			
Class no.	Base alloy	Bare elect. & rods AWS A5.14	Covered electrodes AWS A5.11
1	200	ERNi-1	ENi-1
2	400	ERNiCu-7	ENiCu-7
3	G-3	ERNiCrMo-9	ENiCrMo-9
4	G-30	ERNiCrMo-11	ENiCrMo-11
5	600	ERNiCr-3	ENiCrFe-3 ENiCrFe-2
6	690	ERNiCrFe-7A	ENiCrFe-7
7	625	ERNiCrMo-3	ENiCrMo-3
8	C-22/622	ERNiCrMo-10	ENiCrMo-10
9	C-276	ERNiCrMo-4	ENiCrMo-4
10	59	ERNiCrMo-13	ENiCrMo-13
11	686	ERNiCrMo-14	ENiCrMo-14
12	2000	ERNiCrMo-17	ENiCrMo-17
13	B-2	ERNiMo-7	ENiMo-7
14	B-3	ERNiMo-10	ENiMo-10
15	B-4	ERNiMo-11	-

Procurement guidelines

Table 11 shows the principal wrought nickel and nickel alloys, UNS numbers, and ASTM specification numbers for various product forms. It is often good practice to purchase material to the specifications shown in the table rather than by trade name. In addition to the ASTM Specifications shown in *Table 11* there are four very useful General Requirement Specifications that govern areas common to all alloy grades. The requirements include items such as dimensions and permissible variations, finish and appearance, test methods, inspections requirements as well as sampling descriptions.

The four specifications are as follow:

- ASTM B751 *General Requirements for Nickel and Nickel Alloy Welded Tube*;
- ASTM B775 *General Requirements for Nickel and Nickel Alloy Welded Pipe*;
- ASTM B829 *General Requirements for Nickel and Nickel Alloys Seamless Pipe and Tube*;
- ASTM B906 *General Requirements for Flat – Rolled Nickel and Nickel Alloys Plate, Sheet and Strip*.

Surface finish – The tube and pipe General Requirement Specifications indicate only that the surface should be smooth and free from imperfections that would render it unfit for use. ASTM B906 covers the various finishes for plate, sheet, and strip for nickel and nickel alloys. The requirements of B906 are very similar to ASTM A480 *General Requirements for Flat – Rolled Stainless Steel and Heat-Resisting Steel Plate, Sheet and Strip*. Those familiar with the latter will be comfortable using B906.

Nickel alloy castings

The principal cast nickel alloy designations, UNS numbers, compositions, and wrought counterparts are shown in *Table 8*. The castings are welded using the suggested filler metals for the comparable wrought product shown in *Table 5*. Procurement of nickel alloy castings would seem to be straight forward because all castings are covered by one specification, ASTM A494 *Standard Specification for Castings, Nickel and Nickel Alloy*. Specifying nickel alloy castings to this ASTM specification, however, does not assure quality castings. The best assurance of obtaining quality castings lies with the capability, experience, and integrity of the producing foundry.

Unfortunately, this point is too often overlooked and factors such as price prevail. Large users of castings can profit by visiting potential foundry suppliers to assess their technical and production capabilities. The purchasers should consider the supplemental ordering requirements which follow.

Direct procurement of nickel alloy castings by end users is unusual. The end user normally buys castings in the form of pumps, valves and components already assembled into OEM-furnished equipment. The following considerations

apply to the entity actually purchasing the castings. The supplying foundry should thoroughly review and understand the specifications which must be carefully written by the purchaser.

A very important property of nickel alloys is their corrosion resistance. ASTM A494, to which nickel alloy castings are normally procured for corrosion resisting service, covers composition, mechanical properties, and heat treatment. Corrosion tests are not a part of ASTM A494 and, therefore,

Table 10-B Suggested filler metals for dissimilar metal welds

Alloy	UNS	200 201 CZ100	400 K-500 M35-1	825	G-3	G-30	600 CY40	690	625,725 625Plus® 718, CW6MC	59 686 2000	C-22 622 CX2MW	C-276 CW2M	B-2 B-3 B-4
400 K-500 M35-1	N04400 N05500 N24135	1,2											
825	N08825	1,5,7	5,7										
G-3	N06985	1,3,8	5,6	3,7,8									
G-30	N06030	1,3,4	5	4,7,8	4,7,8								
600 CY40	N06600 N06040	1,5	5	5,7,8	3,7,8	4,7,8							
690	N06690	1,5,6	5,6	5,6,7,8	3,7,8	4,7,8	5,6						
625 725 625Plus® 718 CW6MC	N06625 N07725 N07716 N07718 N26625	1,5,7	5,7	5,7,8	3,7,8,	4,7,8	5,7	5,6					
59 686 2000	N06059 N06686 N06200	1,5,7	5	5,7,8, 10,11 12	3,7,8, 10,11, 12	4,7,8 10,11 12	5,6,10 11,12	5,6,10 11,12	7,8,10 12,13				
C-22/622 CX2MW	N06022 N06022 N26022	1,8	5,6	7,8	3,7,8	4,7,8	5,7,8	5,6,8	7,8	7,8,10, 11,12			
C-276 CW2M	N10276 N26455	1,5,9	5	7,8,9	3,7,8,9	4,7,8, 9	5,7,8, 9	5,6	7,8,9	7,8,9,10, 11,12	7,8,9		
B-2 B-3 B-4	N10665 N10675 N10629	1,13 14,15	13,14 15	7,8,13 14,15	3,8,13 14,15	4,8,13 14,15	7,8,13 14,15	7,8,13 14,15	7,13,14 15	7,8,13, 14,15	8,13, 14,15	9,13 14,15	
4 & 6% Mo stainless steel		1,7,8	5,6	7,8	3,7,8	4,7,8	5,6,7	5,6,7	7,8	7,8	7,8	8,9	8,10
300 Series stainless steel		1,5,6	5,6	7,8	3,7,8	4,7,8	5,6	5,6	7,8	7,8	7,8	8,9	8,10
Carbon and low alloy steels		1,5,6	2	5,6	3,7,8	4,7,8	5,6	5,6	7,8	7,8	7,8	8,9	8,10

require a special arrangement between the purchaser and supplier. In practice, however, corrosion testing of each lot or heat of material is seldom justified except for unusual services. ASTM A990, is another specification for nickel alloy castings with tighter requirements.

There are supplemental requirements that can assist users in obtaining nickel alloy castings which embody the inherent corrosion resistance of these alloys. Source inspections utilising radiographic examination, liquid penetrant examination, weldability tests, and pressure tests are examples of some measures that are available to further control the quality of nickel alloy castings. These additional quality assurance provisions may be specified by the purchaser and should be substantiated by certification

that the foundry complied with the specifications. A few observations concerning the effective use of these supplemental measures follow.

Source inspections

Radiographic inspection – Radiographic inspection should be considered when the castings are subject to high and/or cyclical stresses and when mechanical strength, as well as corrosion resistance, is important. In addition, if surface conditions allow corrosion to proceed beyond the casting surface, subsurface defects may allow the degradation of the longer-term corrosion resistance of the casting. For such applications, radiographic inspection may be justified.

The added expense of radiographic inspection is usually

Table 11 Specifications for procurement of Groups I through IV wrought nickel and nickel alloys

ASTM Specifications unless otherwise noted							
Alloy	UNS	Plate sheet strip	Rod bar forgings	Seamless tube & pipe	Welded tube & pipe	Fittings	Condenser tubing
Group I Nickel & nickel-copper solid solution alloys							
200	N02200	B162	B160 B564	B161	B725 B730	B366	B163
201	N02201	B162	B160	B161	B725 B730	B366	B163
400	N04400	B127	B164 B564	B165	B725	B366	B163
R-405	N04405	N/A	B164	N/A	N/A	N/A	N/A
Group II Chromium-bearing solid solution alloys							
825	N08825	B424	B425 B564	B423	B704 B705	B366	B163
G-3	N06985	B582	B581	B622	B619 B626	B366	B626
G-30	N06030	B582	B581 B462	B622	B619 B626	B366	B626
33	R20033	B625	B649 B564	B622	B619 B626	B366	B626
600	N06600	B168	B166 B564	B167	B516 B517	B366	B163
690	N06690	B168	B166 B564	B167	N/A	B366	B163
625	N06625	B443	B446 B564	B444	B704 B705	B366	B704
C-4	N06455	B575	B574	B622	B619 B626	B366	B626
C-22/622	N06022	B575	B574 B564	B622	B619 B626	B366	B626
C-276	N10276	B575	B574 B564	B622	B619 B626	B366	B626
59	N06059	B575	B574 B564	B622	B619 B626	B366	B626
686	N06686	B575	B574 B564	B622	B619 B626	B366	B163
C2000	N06200	B575	B574 B564	B622	B619 B626	B366	B626
Group III Nickel-molybdenum alloys							
B-2	N10665	B333	B335 B564	B622	B619 B626	B366	B626
B-3	N10675	B333	B335 B564	B622	B619 B626	B366	B626
B-4	N10629	B333	B335 B564	B622	B619 B626	B366	B626
Group IV Precipitation-hardening alloys							
K-500	N05500	QQN286	QQN286 B865	QQN286	QQN286	N/A	N/A
725	N07725	N/A	B805	N/A	N/A	N/A	N/A
625-Plus®	N07716	N/A	B805	N/A	N/A	N/A	N/A
718	N07718	B670	B637	AMS 5589/90	N/A	N/A	N/A

N/A – Alloy is not available in this product form to an ASTM specification

not justified for castings where sound metal on the wetted surfaces and flange faces is the primary service requirement. In such cases, a liquid penetrant examination is a less expensive choice.

Liquid penetrant inspection – Liquid penetrant inspection after rough machining can identify surface defects that may become sites for corrosion and cracking. Wetted surfaces and flange faces inside the bolt circle are examples of surfaces where such defects can be removed with light grinding or minimal weld repair.

Liquid penetrant inspection of non-wetted surfaces can lead to unnecessary cosmetic repairs and should be avoided unless justified by specific need. The fillet areas on the outer surfaces of castings between the bodies and flanges are good examples of areas that are particularly prone to persistent minor penetrant indications. These indications are usually inconsequential and difficult to eliminate completely.

Weldability test –The weldability test as specified in ASTM A494 is optional, but can be one of the best assurances that the heat or lot does not have harmful levels of trace elements and that the heat treatment, if required, has been properly performed. The test, *Figure 1(b)* of ASTM A494, is the preferred test and includes a bend test and macro examination.

Tramp or unwanted elements usually result from poor quality starting material and scrap circuit control. Foundries with good quality control programs seldom encounter weldability problems.

The purchaser must decide how extensively the weldability test should be applied, i.e., to every heat of material or to a selected or random number of heats. Generally, the test should be applied to all heats supplied by a new foundry source. It is prudent to follow the same policy for alloys new to a particular foundry until a confidence level has been established.

Pressure test – Hydrostatic or air testing is performed by many foundries on pressure-type castings. Although these tests are not a requirement of ASTM A494, they should be specified as an additional requirement. Pressure tests should be performed after rough machining and before weld repair.

Certification –To assure that the requirements have been met, the purchaser can, and should, request the manufacturer's certification stating that the material was manufactured, sampled, tested, and inspected in accordance with the full material specification including all supplemental tests requested.

Heat treatment – *NiCrMo alloys* – ASTM A494 requires a solution annealing temperature of 1175 °C (2150 °F) minimum followed by a water quench for the NiCrMo alloys: CW6MC, CW2M, and CX2MW shown in *Table 8*. Experience has shown that a solution annealing temperature of 1220 °C (2225 °F) is better for alloys CW2M and CX2MW. The annealing temperature as well as the water quench can present problems to some suppliers. The higher furnace temperature is needed to dissolve potentially harmful precipitates. The water quench is needed to ensure that these potentially harmful precipitates do not precipitate out during cooling.

Many foundries do not have furnaces capable of reaching the required solution annealing temperatures. They may offer to heat treat at somewhat lower temperatures for longer times. Both of these exceptions are detrimental to the finished product quality and should be refused. Lower solution annealing temperatures allow precipitates to form which are harmful to corrosion resistance and longer times allow more of the harmful precipitates to form. To verify that these conditions do not occur, procurement documents should require that furnace charts be supplied showing that the specified solution annealing temperature was actually reached.

Some foundries may request exception to a water quench fearing that the casting may crack. While the water quench is an excellent check on general quality in addition to preventing precipitation of undesirable second phases, there may be configurations that are prone to cracks. These need to be reviewed on a case by case basis by qualified and experienced metallurgical specialists. No exception to the water quench test should be allowed without this qualified evaluation.

Nickel, Nickel-Copper, Nickel-Molybdenum alloys – Ni, NiCu and NiMo alloys are less sensitive to heat treatment and weld

repair than NiCrMo alloys. Nickel and NiCu do not require a solution annealing treatment and are used in the as-cast condition. NiMo alloys are annealed at a temperature of 1095 °C (2000 °F) followed by a water quench. A temperature of 1095 °C (2000 °F) is easily reached in most alloy foundry furnaces.

Chemistry – It is essential that the alloy composition of all nickel alloys be within the ranges specified by ASTM A494, however, not all of the tramp elements which can be deleterious to the welding of nickel alloys or to their corrosion resistance are identified in ASTM A494.

The composition of the as-cast surface of the casting may differ from the specified composition due to carbon pickup from some molding materials, chromium depletion during annealing, or other casting-related surface changes. When the casting is machined, the surface layer is removed and the composition of the machined surface closely approaches the bulk chemistry.

The following three suggestions can help to ensure the chemical integrity of the castings you receive.

1. Require a weldability test, described earlier, to assure that tramp elements are not present in an amount to cause defects from welding.
2. Assure that the foundry has the capability to make reliable chemical analyses. This can be confirmed by an audit performed by a qualified analytical chemist and/or by a check analysis performed by an outside laboratory skilled in analysing nickel alloys.
3. When the as-cast surface is the surface that must resist corrosion, it is prudent to require that the composition at the surface be within the ranges applicable to the particular alloy.

Casting repair by welding

It is good practice to rough-machine and pressure-test all nickel alloy castings before weld repairs are made. This procedure allows weld repairs to be made before final heat treatment and avoids most of the problems that arise when defects are uncovered in machining.

Major weld repairs are defined in ASTM A494. Welding heats the area adjacent to the weld into a range where phases may

precipitate that can be deleterious to corrosion resistance of the NiCrMo alloys. Post-weld heat treatment (PWHT) and rapid quenching after weld repairs restores full corrosion resistance – if and only if – the high temperatures required for solution annealing are actually reached.

Ni, NiCu and NiMo alloys, Group I and III alloys – Although welding heats the area adjacent to the weld of Ni, NiCu and NiMo alloys to high temperatures, there are no deleterious phases that precipitate in these solid solution alloys. Since PWHT is not required, procurement is simplified.

Filler metals – The filler metals shown in *Table 5* should be used for all weld repairs unless experience has shown over-matching composition filler metals are required for the specific environment of concern. An example of a need for an alternate filler metal is discussed earlier in Part II, in the topic entitled *Salt & brine environment*. (pg.31)

Post-weld repair heat treatment – If specified in ordering, a post-weld heat treatment can be required after major weld repairs to grades N7M, N3M, CW6M, CW2M, CX2MW, and CW6MC. For severe corrosion services, this post-weld heat treatment is often advisable. The heat treatment is to be performed using the same annealing temperatures and quench procedure specified for the particular grade. The Ni and NiCu cast alloys usually do not receive a post-weld repair heat treatment.

Welding nickel alloy castings

The guidelines for welding wrought nickel alloys covered in Part I should also be used in welding nickel alloy castings, whether making casting repairs or incorporating the castings into fabrications. All oil, grease, machining lubricants and similar substances should be removed with a suitable solvent. All surface oxides and “casting skin” should be removed next to the weld joint by machining or abrasive grinding. Failure to remove this layer usually contributes to weld defects. Abrasive grinding wheels should be dedicated to grinding only nickel alloy castings and should not be previously used on carbon or low alloy steel.

In fabrication welding, nickel alloy castings are joined with the same welding processes used for the wrought forms. In the repair of castings, the welding process employed often depends upon the size of the casting and size of the defect.

GTAW is the process of choice in repairing small castings and in repairing small, shallow defects on any size of casting. Similar composition filler metal should be added in making GTAW repairs. The SMAW process is often used by foundries for the repair of larger defects and has the advantage of lower heat input than GTAW for similar repairs. Foundries have also developed GMAW procedures for welding repair and are able to realise greater welding efficiencies.

Procurement checklist for nickel alloy castings

In procurement, recognise that nickel alloys have been selected for their excellent corrosion resistance. Using ASTM Specifications is an essential first step, but does not protect the user from receiving nickel alloy castings with degraded corrosion resistance. Assurance of quality is up to the purchaser and the supplemental requirements he places on the foundry, above and beyond the basic ASTM requirements. Following is a checklist of requirements supplementary to those in ASTM A494 that are frequently necessary in order to obtain the quality and corrosion resistance inherent in the basic composition:

1. Source inspections, including one or more of the following:
 - a. Radiographic inspection;
 - b. Liquid penetrant inspection;
 - c. Analysis of surface and/or bulk chemistry by supplier or by a qualified laboratory;
 - d. Weldability tests;
 - e. Rough machining and pressure tests;
 - f. Certification.
2. Process control requirements and verification:
 - a. Higher solution annealing temperature;
 - b. Furnace charts;
 - c. Water quench;
 - d. Weld repair and post-weld repair heat treatment.

Part III

For the design engineer

Design for corrosion service

Thoughtful design can improve corrosion resistance and obtain better service from less expensive grades of nickel alloys. There are two cardinal rules to keep in mind.

1. Design for complete and free drainage.
2. Eliminate or seal weld crevices.

Tank bottoms

Figures 13 through 18 shows six common tank bottom designs. The square-corner-flat-bottom design shown in Figure 13 invites early failure from the inside at the corner

Figure 13 Flat bottom, square corners—worst

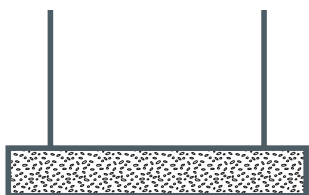

Figure 14 Flat bottom, rounded corners—good corners—poor outside

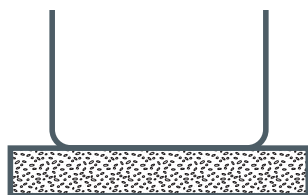

Figure 15 Flat bottom, rounded corners, grouted—good inside, poor outside

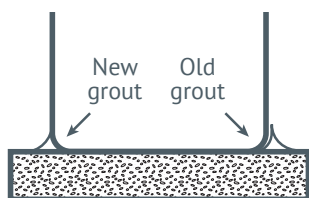
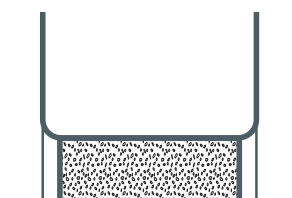

Figure 16 Flat bottom, rounded corners, drip skirt—good inside, good outside



weld where sediment collects, increasing the probability of under sediment crevice attack. In addition, the flat bottom-to-pad support invites rapid crevice corrosion when moisture penetrates the underside.

The rounded-bottom design shown in Figure 14 is much more resistant from the inside, but is actually worse from the outside as condensation is funneled directly into the bottom-to-pad crevice. The grout used to divert such condensation, Figure 15, helps initially, but soon shrinks and becomes a source of maintenance.

The drip skirt shown in Figure 16 is the best arrangement for flat-bottom tanks. The concave bottom and the dished-head bottom on supports, Figures 17 and 18, are very good and are superior to all flat-bottom tanks not only in corrosion resistance but also in fatigue resistance.

Fatigue stresses from filling and emptying are seldom considered in design, but they can be significant and have led to failures in flat-bottom tanks. The concave and dished-head designs can withstand much greater fatigue loadings than can flat bottoms.

Figure 17 Concave bottom, rounded corners—good inside, good outside, fatigue resistant



Figure 18 Dished head—best inside, best outside, fatigue resistant



Tank bottom outlets

Residual fluid in the bottom of nickel alloy tanks is a potential source of tank bottom failures. Side outlets and centre outlets shown in *Figures 19* and *20* provide a convenient construction configuration but invite early failure of tank bottoms. Not only is a layer of stagnant liquid held on the tank bottom, but sediment and accumulated contamination cannot easily be flushed out. The flush side outlet and the recessed bottom outlet as shown in *Figures 21* and *22* allow the bottom to be completely drained of sediment, leaving it clean and dry. The sloped designs shown in *Figures 23* and *24* improve further on these designs, facilitating the drainage of residual liquid and sediment.

Figure 19 Side outlet, above bottom—poor



Figure 20 Centre outlet, above bottom—poor



Figure 21 Side outlet, flush—good



Figure 22 Centre outlet, recessed—good



Figure 23 Side outlet, flush, sloped—best

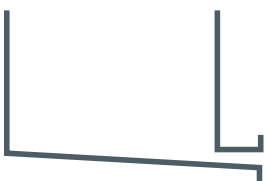
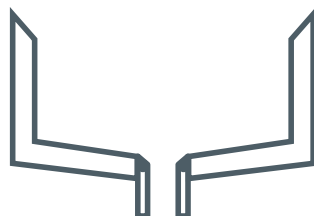

Figure 24 Centre outlet, recessed, sloped—best



Bottom corner welds

When the sidewall forms a right angle with the bottom, the fillet weld is seldom as smooth as shown in the cross section of *Figure 25*. It is usually rough and it frequently varies in width to compensate for variations in fit-up. Sediment tends to collect along the weld. It is difficult to remove, and leads to under-sediment crevice attack. Welding along the outside as shown in *Figure 26* improves the resistance of the joint to crevice attack from the outside; however, rounding the corner and moving the weld to the sidewall as shown in *Figure 27*, improves it further. The corrosion resistance from both sides as well as the fatigue resistance are improved by this last refinement.

Figure 25 Corner weld from inside—poor inside, worst outside

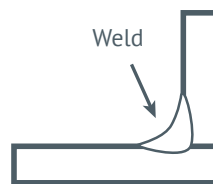

Figure 26 Corner weld from both sides—poor inside, good outside

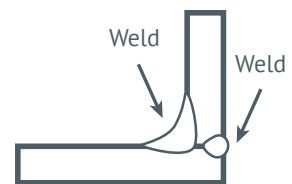
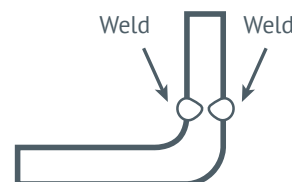

Figure 27 Side wall in lieu of corner weld—best inside, good outside, fatigue resistant



Attachments and structurals

Attachments create potential crevice corrosion sites. *Figure 28* shows a tray support angle with intermittent welds made with the intention of providing adequate strength, however, there is a severe crevice between the angle and the inside wall of the vessel. Over time, this crevice fills with sediment and other contaminants, inviting premature failure from crevice corrosion.

Figure 29 shows the same tray support with a continuous seal weld at the top. This change prevents contaminants from migrating into the crevice. The angle-to-sidewall

Figure 28 Tray support, staggered strength weld—severe crevice

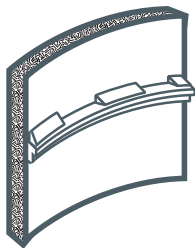

Figure 29 Tray support, full seal weld top—good crevice resistance

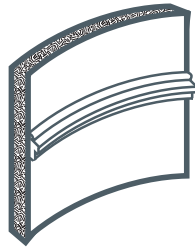

Figure 30 Tray support, full seal weld top and bottom—best crevice resistance

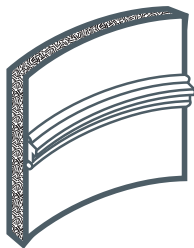

Figure 31 Reinforcing pad, staggered welds—adequate strength

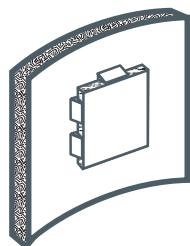
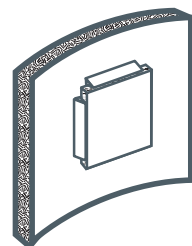

Figure 32 Reinforcing pad, seal weld—best crevice resistance



crevice is still open from the bottom, but this is a much less severe crevice. While this crevice is still subject to vapour penetration, it is not vulnerable to the lodging of solids. *Figure 30* shows a full seal weld at the top and bottom of the tray support angle. With this addition, the crevice is fully sealed and represents the best design for crevice corrosion resistance.

Figure 31 shows a reinforcing pad frequently used to weld other attachments. The intermittent weld creates a severe pad-to-sidewall crevice inviting premature failure. Completing the seal weld as shown in *Figure 32* requires very little additional time but greatly improves the corrosion resistance of the pad.

Figure 33 shows structural angles positioned to allow drainage, an important factor in preventing crevice corrosion. Angles should never be positioned as shown in the top view of *Figure 34*. The best position for complete drainage is shown in the lower view.

When structural shapes are used, they should be positioned with open side down so that liquids will drain freely. When this preferred positioning is not possible, drain holes should be drilled about every 300 mm (12 in.) in the center as shown in the middle view of *Figure 35*.

Figure 33 Position of angles

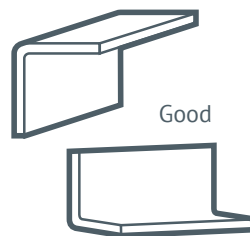

Figure 34 Position of angles

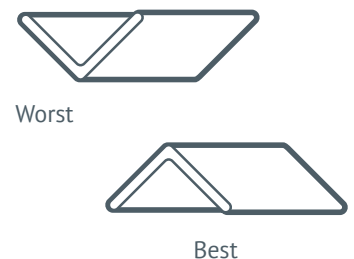

Figure 35 Position of channels



Continuous fillet welds on stiffeners and baffles, as shown on the right side of *Figure 36*, seal the severe stiffener/baffle-to-horizontal-plate crevice. The staggered fillet welds shown on the left side of *Figure 36* leave the joint vulnerable to crevice corrosion.

Baffles in tanks and heat exchangers create dead spaces where contaminants and sediment can collect and where full cleaning is difficult. *Figure 37* shows a cut-out at the lower corner of a tank baffle and *Figure 38* shows a cut-out in the lower portion of a heat exchanger tube support plate. Both arrangements reduce the likelihood of the accumulation of contaminants and facilitate cleaning.

Heaters and inlets

Heaters should be located so they do not cause hot spots on the vessel wall. In *Figure 39*, the poor location of heaters creates hot spots which, in turn, may result in higher corrosion in the area between the heater and the vessel

wall. The good design avoids hot spots by centrally locating the heater.

When a concentrated solution is added to a vessel, it should not be introduced at the side as shown in the poor design of *Figure 40*. Side introduction causes concentration and uneven mixing at the sidewall. With the good design, mixing takes place away from the sidewall. It is also good design practice to introduce feed below the liquid level to avoid splashing and drying above the liquid line.

Pipe welds

Small diameter nickel base alloy piping, 25 mm (1 in.) and less in diameter may be socket welded rather than butt welded. Fortunately, the wider use of automatic orbital welding has greatly reduced the use of socket welds. The crevice of a socket weld joint is less damaging to nickel alloys than to stainless steel due to the considerably greater corrosion resistance of the nickel alloys. Nevertheless, the

Figure 36 Stiffeners and baffles

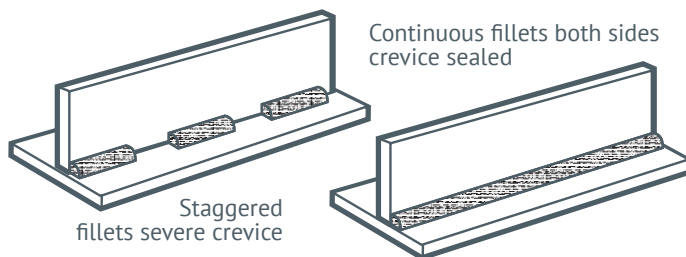

Figure 37 Corner baffle cut-out—good

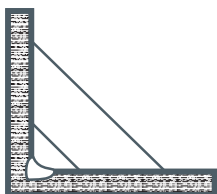

Figure 38 Heat exchanger, baffle cut-out—good



Figure 39 Poor and good designs for the location of heaters in a vessel

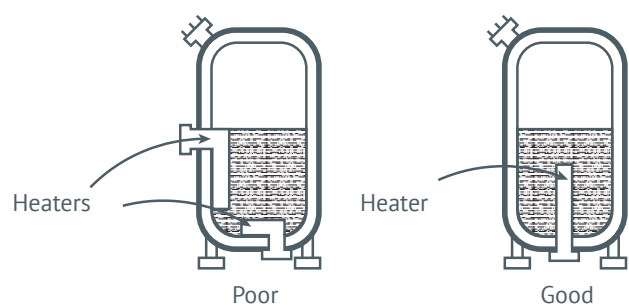
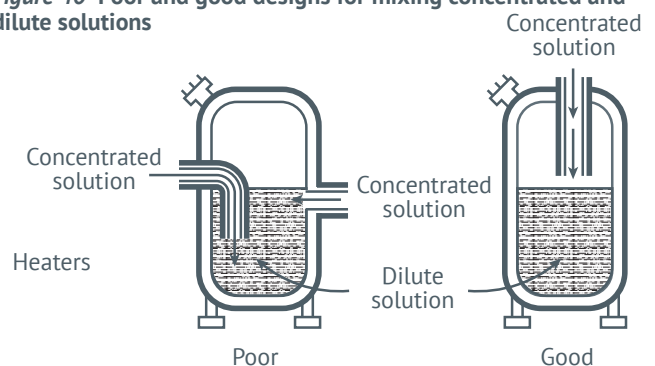

Figure 40 Poor and good designs for mixing concentrated and dilute solutions



crevice provides a site of lower corrosion resistance in some aggressive environments. To circumvent this weakness, specify orbital butt welds wherever practical.

Figure 41 shows a circumferential pipe weld with incomplete penetration. Pipe welds should be full penetration welds for best corrosion performance and for full weld joint efficiency. Welding codes such as those of the American Society of Mechanical Engineers (ASME) and the American Petroleum Institute (API) require full penetration butt welds. When such codes are not imposed, the purchaser should specify that pipe welds be full penetration welds. In addition, limits should be placed on the weld concavity and convexity. Common limits are maximums of 0.8 mm (0.03 in.) concavity and 1.6 mm (0.06 in.) convexity.

Three typical pipe-to-flange welding designs are shown in Figures 42, 43, and 44. The recessed arrangement shown in Figure 42 avoids the need for machining or grinding smooth

the surface of the weld on the flange face in Figure 43. Both of these are suitable when the flange is of the same material as the pipe. Neither is suitable when carbon steel or ductile iron flanges are used on nickel alloy pipe. In this case a stub-end arrangement as shown in Figure 44 is preferred.

In order for piping and heat exchanger tubing to drain completely, it is necessary to slope the piping or heat exchanger tubing just enough so that water is not trapped in the slight sag between supports. Figure 45 shows how a water film tends to remain in horizontal runs of pipe or tubing, and how water drains when sloped.

Figure 41 Pipe weld with incomplete penetration—severe crevice

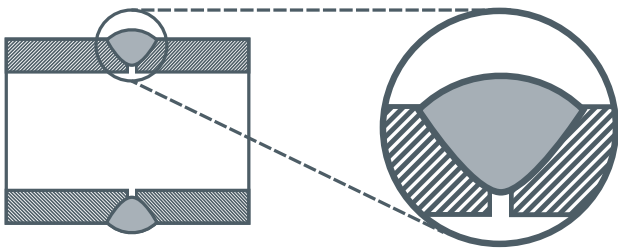

Figure 44 Stub-end, flange carbon steel or ductile iron—very good

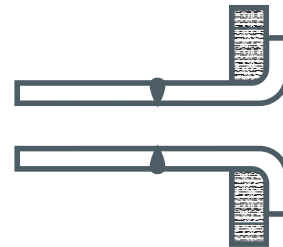

Figure 42 Pipe recessed, flange and pipe, same alloy—good

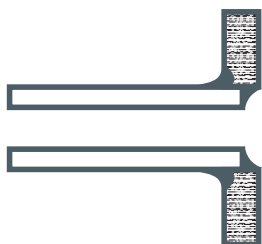

Figure 43 Pipe flush, flange and pipe, same alloy—better

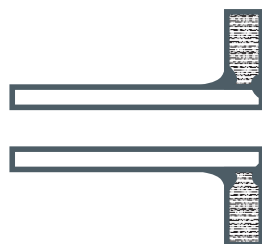
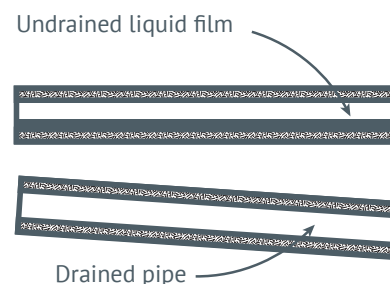

Figure 45 (A) Horizontal (standard)—poor
(B) Sloped—very good



Weld overlay, sheet lining, and clad plate

To offset the relatively high cost of solid nickel alloy construction and still provide a highly corrosion-resistant layer of alloy, weld overlaying, sheet lining, or clad steel plate are often viable design options. Construction using these techniques or products is well-suited to those applications where the full metal thickness is not required for mechanical purposes or corrosion resistance. For economic reasons, the backing material is usually carbon steel, but other steels are feasible. Some features of the three designs are summarised in *Table 12*. A discussion on welding and fabrication techniques of each of the processes follows.

Weld overlay

Weld overlay surfacing is well-suited to covering thick sections of items such as tube sheets, large diameter shafts, and the walls of thick-section pressure vessels. The substrate is usually carbon steel or, on occasion, a low alloy steel. The weld overlay may be made by a number of different welding processes; the choice is usually based on the process that gives the highest deposition rate and acceptable quality overlay for the particular application.

Comments on the welding processes for overlay welding follow.

Submerged arc welding – Deposition rates using SAW are high, a 35 to 50% increase over GMAW overlay capability. SAW fluxes are commercially available for use with most of the common nickel alloy bare wire and strip filler metals. With wire electrodes, a diameter of 1.6 mm (0.062 in.) yields better results than the larger diameters characteristic of steel or stainless steel SAW. Strip filler metals are typically available in 0.5 mm x 60 mm (0.02 in. x 2.36 in.) and in 0.5 x 30 mm (0.02 in. x 1.18 in.). Base metal dilution is normally controlled so that only two weld layers are needed unless the surface is to be machined, in which case three weld layers may be required. The as-welded surfaces are smooth enough to be dye-penetrant inspected with no special surface preparation other than wire brushing. All welding must be done in the flat position unless the equipment is specially adapted for horizontal welding.

Gas metal arc welding – GMAW overlays are usually made using the spray arc or pulsed arc mode. The spray arc mode has the advantage of higher deposition rates, but all welding must be performed in the flat position. Base metal

Table 12 Comparisons of weld overlay, sheet lining, and clad plate

Design	Applications	Remarks
Weld overlay	Covering substrate sections of unlimited thickness and varied shapes, such as tube sheets Multi-layers (2 or 3 minimum) needed to compensate for dilution	Provides solid bond of alloy to substrate providing good heat transfer and mechanical strength Generally not competitive where sheet lining or clad plate is acceptable Useful for local repair of alloys in process equipment
Sheet lining	Covering broad areas of existing or new construction substrate with thin alloy sheet Extensive sheet forming is required in applying to complex shapes	Adoptable to applying liner to selective high corrosion/erosion areas Not suited to vacuum or heat transfer applications Need for plug welds for mid-sheet attachment
Clad plates	Constructions where large size plates are an advantage Roll-bonded plates limited to 64-76 mm (2.5-3 in.) thickness or explosion-bonded backing plates may be several inches thick	Where an integral bond between alloy and backing is needed for vacuum or heat transfer applications or for construction of storage and pressure vessels Tight welding controls are required for minimum iron dilution on the alloy side

dilution tends to be higher with GMAW welding than with other processes. The favoured method employs automatic welding with an oscillating torch movement.

Pulsed GMAW overlays are usually done with a filler wire diameter of 1.2 mm (0.045 in.), compared to a wire diameter of 1.6 mm (0.062 in.) used with the spray arc mode. Deposition rates are lower, but all-position welding is possible. Pulsed arc mode GMAW may be done with either manual or automatic set-up.

Shielded metal arc welding – Deposition rates are relatively low, but the process is useful in overlaying small areas and irregular, out-of-position surfaces where automation is not justified. Facings on vessel outlets and trim on valves are good examples of suitable applications.

Weld overlay guidelines – The effect of base metal dilution and the profile of the overlay/base metal interface are two areas of concern in weld overlay work. These concerns are common to overlays made with any welding process.

Base metal dilution – Usually the objective is to provide a weld overlay in which the top weld surface has a composition equivalent to the base metal type to achieve a similar corrosion resistance. For example, the top weld layer of a nickel-copper overlay should be equivalent to that of alloy 400. This means a minimum of two weld layers and often three along with careful control of welding parameters to minimise penetration into the base metal. Each additional layer adds significantly to the total cost, so there is a strong incentive to minimise the number of weld layers. Two ways to do this follow:

- Where the overlay composition is a chromium-bearing alloy containing iron, use a low iron, high alloy filler metal. This suggestion might be implemented, for example, by substituting filler metals such as ERNiCrMo-3, ERNiCrMo-4 or ERNiCrMo-10 in an overlay weld which calls for alloys such as 825 or G-3.
- For nickel and nickel-copper overlays, do not specify lower iron limits than are needed for satisfactory corrosion performance.

Base metal interface – The second concern is the interface profile. Ideally the interface profile perpendicular to the direction of welding should be a nearly straight line, free of “spikes” of base metal between weld beads. An uneven profile is more prone to weld cracking and may fail to pass a side bend test which is often required by codes.

Sheet lining

Sheet lining has been used for over 80 years to cover metal substrates with a more corrosion-resistant alloy. Stainless steels, nickel, and copper alloys are common lining alloys. Essentially the same application technique is used for all alloys. The sheet characteristics and the welding practices used in the sheet lining process are summarised below; further details are available in NI technical series publications No. 10 027 and 10 039 which are included in the Reference Document section.

- The substrate surface should be thoroughly cleaned, such as by abrasive blasting, prior to welding the alloys sheets to the substrate. See Part I for further pre-welding cleaning and preparation practices.
- Sheet thickness/size – A sheet thickness of 1.6 mm (0.062 in.) is most widely used; thinner sheet is more difficult to weld. To minimise the amount of welding, the sheet sizes used are as large as are practical to form and handle.
- The liner weld joint most widely used is the overlap joint shown in *Figure 46*. The overlap joint is easy to use with 1.6 mm (0.062 in.) sheets and avoids dilution from the substrate. The three-bead method is more often used for alloy sheets that are 3.2 mm (0.125 in.) and thicker.
- Mid-sheet attachments, when needed, are often used when lining larger-sized sheets to minimise the chance of vibration or flutter. The attachment method is typically made by plug welds using pre-punched holes.
- Seal welds can be made by SMAW or GTAW, but the pulsed GMAW process is most widely used.

Clad steel plate

Nickel alloy clad steel plate is available as either a roll-bonded or explosion-bonded product. Roll bonded clad is

produced by hot-rolling a thick section sandwich of steel and alloy starter plates. In the course of hot-working, a metallurgical bond is formed between the two metals. The normal thickness of roll-bonded clad plates is 5 mm (0.187 in.) up to 64-76 mm (2.5-3 in.) with the alloy representing 10 to 20 % of the total thickness. In explosion-bonding, there is usually no reduction after bonding, so the starting and finish alloy and steel thicknesses are the same. This allows relatively thin alloy sheet to be applied to backing steel several inches thick.

Figure 46 Weld joints for liners

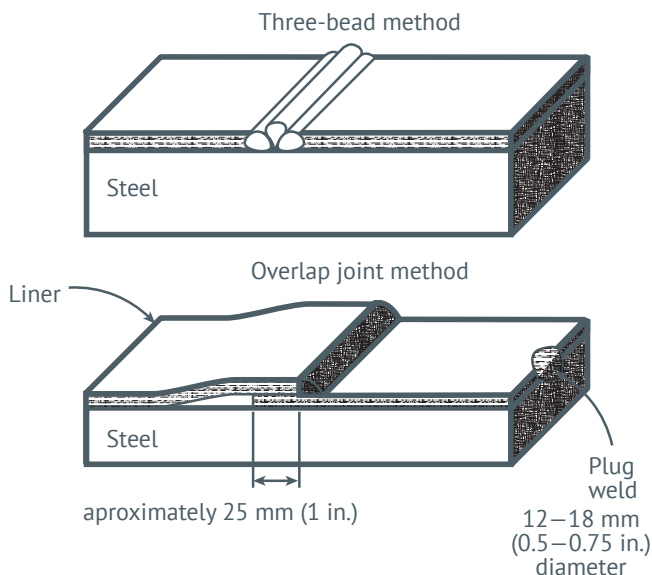
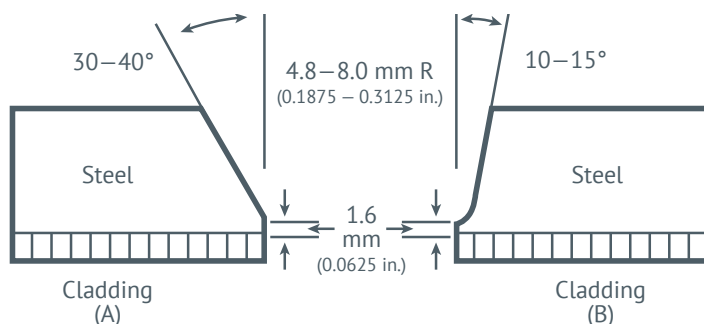

Figure 47 Joint designs for clad steel. (A) Material 4.8 to 16 mm (3.0625 to 0.625 in.) thick. (B) Material 16 to 25 mm (0.625 to 1 in.) thick (courtesy of Inco Alloys International—Joining Technical Bulletin)



Recommended joint designs for butt welding clad steel are shown in *Figure 47*. Both designs include a small root face of steel, i.e., the edge of unbeveled portion of the joint, above the cladding to protect the cladding during welding of the steel. The steel side should be welded first with a steel filler metal, often by SMAW with a low hydrogen electrode on the first pass. It is important to avoid penetration into the cladding when welding the first pass. Dilution of the steel weld with the nickel alloy cladding can cause weld cracking. Upon completion of the steel side, the clad side is prepared by grinding or chipping. Welding is done with the filler metal recommended for welding solid alloy sections in *Table 5*. To compensate for dilution by steel, at least two layers should be applied.

Light thickness clad plates are usually more economically welded using the nickel filler metal for both sides of the joint. Refer to references 21, 22, 23 and 24 listed in the Reference Documents for further details on welding roll-bonded clad metals.

Explosion clad plates are fabricated and welded using essentially the same procedures use with roll-bonded plates.

Safety and welding fumes

Safety rules for welding nickel alloys are essentially the same as for all metals as they pertain to areas such as electrical equipment, gas equipment, eye and face protection, fire protection, labeling hazardous materials, and similar items. The American Welding Society publishes a good reference guide on welding safety, entitled *Safety in Welding and Cutting* (American National Standard Institute/Accredited Standards Committee, ANSI/ASC Z49.1).

Many welding, cutting and allied processes produce fumes and gases which may be harmful to one's health. Fumes are mixtures of fine solid particles and gases which originate primarily from welding consumables with a minor amount from the base metal. In addition to shielding gases that may be used, gases are produced during the welding process or may be produced by the effects of process radiation on the surrounding environment. Acquaint users with the effects of these fumes and gases. The amount and composition of these fumes and gases depend upon the composition of the filler metal and base material, welding process, current level, arc length and other factors.

Compounds of chromium, including trivalent and hexavalent chromium, and of nickel may be found in fume from welding processes. They originate almost entirely from the filler material, with only a small contribution from the base metal. The specific compounds and concentrations will vary with the composition of the base metals, the welding materials used, and the welding processes. Immediate effects of overexposure to welding fumes containing chromium and nickel are similar to effects produced by fume from other metals. The fumes can cause symptoms such as nausea, headaches, and dizziness. Some persons may develop a sensitivity to chromium or nickel which can result in dermatitis or skin rash.

To protect against the effect of overexposure to chromium and nickel in welding fume, do not breathe fumes and gases. Keep your head out of fumes. Use enough ventilation or exhaust at the arc, or both, to keep fumes and gases from your breathing zone and general area. In some cases, natural air movement will provide enough ventilation. Where ventilation may be questionable, use air sampling to determine if corrective measures should be applied.

Refer to the current edition of AWS G2.1M/G2.1 for additional safety information.

Reference documents

1. American Welding Society-AWS B2.1, *Specification for Welding Procedure and Performance Qualification*.
2. American National Standard Institute/Accredited Standards Committee.
3. ANSI/ASC Z49 1, *Safety in Welding and Cutting*.
4. ASTM A 380, *Standard Practice for Cleaning, Descaling, and Passivation of Stainless Steel Parts, Equipment, and Systems*.
5. AWS G2.1M/G2.1, *Guide for the Joining of Wrought Nickel-Based Alloys*
6. AWS A5.11/A5.11M, *Specification for Nickel and Nickel-Alloy Welding Electrodes for Shielded Metal-Arc Welding*
7. AWS A5.14/A5.14M, *Specification for Nickel and Nickel-Alloy Bare Welding Electrodes and Rods*
8. AWS A5.34/A5.34M, *Specification for Nickel Alloy Electrodes for Flux Cored Arc Welding*
9. ANSI/AWS D10.11, *Recommended Practices for Root Pass Welding of Pipe Without Backing*.
10. ASM International Metals Handbook, Volume 6, *Welding, Brazing, and Soldering*.
11. ASME Boiler and Pressure Vessel Code, Section IX, *Welding and Brazing Qualifications*.
12. *Fabrication of HASTELLOY® Corrosion Resistant Alloys*, Haynes International Inc., Kokomo, in.
13. *Guidelines for the Welded Fabrication of Nickel-Containing Stainless Steels for Corrosion Resistant Services*, NI Technical Series No. 11 007.
14. *Guidelines for Welding Dissimilar Metals*, by Richard E. Avery, NI Technical Series No. 14 018.
15. *Joining Technical Bulletin*, Special Metals Welding Products Company, Newton, NC.
16. *Specifying Stainless Steel Surface Treatment*, by Arthur H. Tuthill and Richard E. Avery, NI Technical Series No. 10 068.
17. *Stainless Steel Sheet Lining of Steel Tanks and Pressure Vessels*, by Richard E. Avery, Jonathan D. Harrington, and William L. Mathay, NI Technical Series No. 10 039.
18. *The Affect of Heat-Tint on Corrosion Resistance of Alloys Used in FGD Systems*, by W.L. Silence and L.H. Flasche, Paper 358 NACE CORROSION '86.
19. *The Back Purging and Welding Requirements for Fabrication of HASTELLOY® Alloy Pipe Systems*, Haynes International, Inc., Huntington, WV.
20. *Welding and Fabrication of Nickel Alloys in FGD Systems*, by Richard E. Avery and W. H. D. Plant, NI Technical Series No. 10 027.
21. *Engineering with CLAD STEEL*, NI Technical Series 10064
22. NACE SPO199, *Installation of Stainless Chromium-Nickel Steel and Nickel-Alloy Roll-Bonded and Explosion-Bonded Clad Plate in Air Pollution Control Equipment*
23. *Clad Steel Plate*, JFE Steel Corporation
24. *Roll-Bonded Clad Plates*, voestalpine Grobblech GmbH

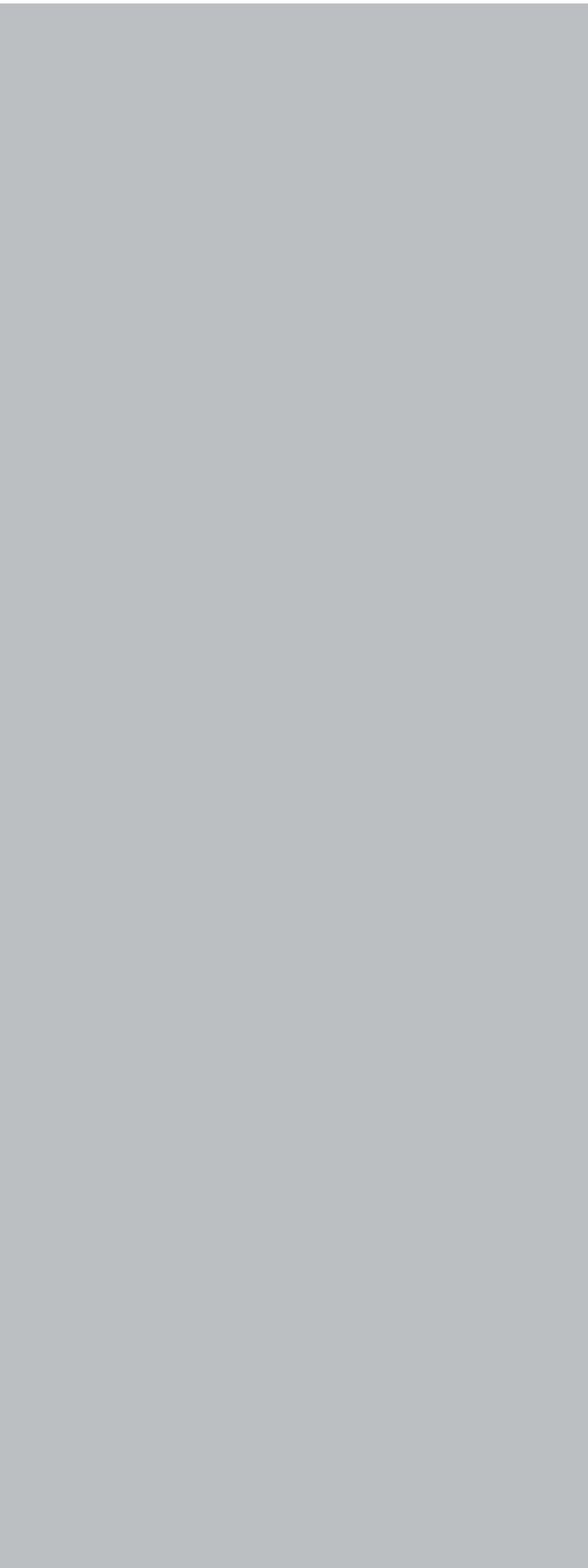



knowledge for a brighter future

Nickel Institute

communications@nickelinstitute.org
www.nickelinstitute.org

.....
Published 2018