

# AlcoTec Aluminum Technical Guide





# AlcoTec Aluminum Wire & Equipment Technical Guide

## Table of Contents

Environmental Health and Safety .....	3
<b>Technical Services</b>	
Heat Treatable & Non-Heat Treatable Base & Fillers .....	6
Filler Alloys: Chemical Composition Limits & Physical Properties .....	7
Conversion Factors .....	7
Welded Joint Strength .....	8
Typical Tensile Properties - Groove Welds .....	9
Weld Profiles.....	10
Weld Control Characteristics .....	11
Parameter Changes & Current Density.....	11
Backing Bars .....	12
Bend Testing Aluminum .....	13
Atmospheric Conditions Affect Weld Quality .....	14
Feedability .....	15
Excessive Face Reinforcement .....	16
Dilution .....	17
Aluminum Alloys .....	18
Heat-Treatable and Non Heat-Treatable Alloys & the Heat Affected Zone (HAZ) .....	19
Considerations When Repairing Aluminum Structures .....	20
Shielding Gas for Arc Welding Aluminum .....	21
Easy Weld Quality Tests.....	22
Weld Cracking .....	24
Performance Improvement - Increasing Wire Diameter .....	26
Filler Alloy for Welding 6061-T6.....	27
The Affect of Texture on Anodizing.....	28
Recommended Welding Parameters .....	29
Aluminum Filler Alloy Chart .....	30
<b>Education</b>	
Welder Certification and Qualification .....	34
AlcoTec School of Aluminum Welding Technology .....	35
AlcoTec School of Aluminum Welding Technology Course Outline .....	36
Classroom .....	36
Laboratory .....	36

## The AlcoTec® advantage.

At AlcoTec®, aluminum welding isn't just part of our business, it's our only business. Since 1984, AlcoTec aluminum wire has been world renowned for quality, consistency, and performance.

And premium aluminum wire is just the start of what we offer. Our goal is to help you work smarter, faster, and better. With continuous innovation, we maximize your productivity while minimizing your costs by:

- Providing service and support that goes the extra mile to keep you up and running
- Helping you take your aluminum welding skills to the next level through expert training
- Becoming the ultimate partner you can trust for years to come

At AlcoTec, integrity is just as important to us as the quality of our product. We strive to treat everyone with the utmost respect. We measure our success by the number of long-term customers who trust us and value what we bring to the table. And we appreciate it when our customers say how much they like working with us.

We invite you to get to know AlcoTec's products, equipment, and technical services.

**Our mission:** To provide our customers with the most cost-effective solutions for their welding and cutting applications. Through technological leadership, the most reliable products and deliveries, and continuous improvement of our processes, we will delight our customers, employees, shareholders, and community.

**Our values:** Integrity, Progress, Quality, Leadership, and Teamwork.

**“We take the concerns  
of our customers to heart!”**

– Todd Peters, Operations Manager, AlcoTec Wire Corporation

## **Environmental Health and Safety**

At AlcoTec, we put a heavy emphasis on environmental health and safety, and are constantly looking for ways to improve our operations. Our facilities and products meet or exceed all applicable governmental requirements and standards. We educate and encourage our employees to comply with EHS policies.

AlcoTec is a subsidiary of ESAB Group, Inc., - the first global company to achieve both ISO 14001 (1999) and OHSAS 18001 (2006) certifications. Furthermore, we are proud to be ISO 9001 certified.





# Technical Services



## No one knows aluminum welding better.

We are your tried and true aluminum welding experts. Unlike other manufacturers who deal with multiple welding processes, we specialize solely in aluminum. This allows us to provide an unmatched array of services from experienced engineers and technicians - expertise you won't find anywhere else.

As an AlcoTec partner, help is always available. Our Customer Service Specialists work directly from our manufacturing facility, so you'll work with a factory-based technician who can help you with everything from troubleshooting to checking on the status of an order. You can even arrange a consultation with one of our industry-leading Metallurgical or Welding Engineers.

Our team of Field Specialists have been technically trained to personally solve simple problems to complex issues. You can reach our Service Team by phone, email, Facebook, or our website. Either way, you can look forward to a prompt, thorough response to your question.

**“I absolutely recommend AlcoTec. They're more than a wire company. They fix issues that aren't really their problems.”**

– Rusty Beckner, AlcoTec customer

### Get the most from your application

As a specialized process, there are many factors to consider when welding aluminum that will determine the effectiveness of your application. This section details some of the more critical technical specifications that will help you get the most from your aluminum welding application.

## Heat Treatable & Non-Heat Treatable Base & Fillers

Aluminum Alloy Designation Tree

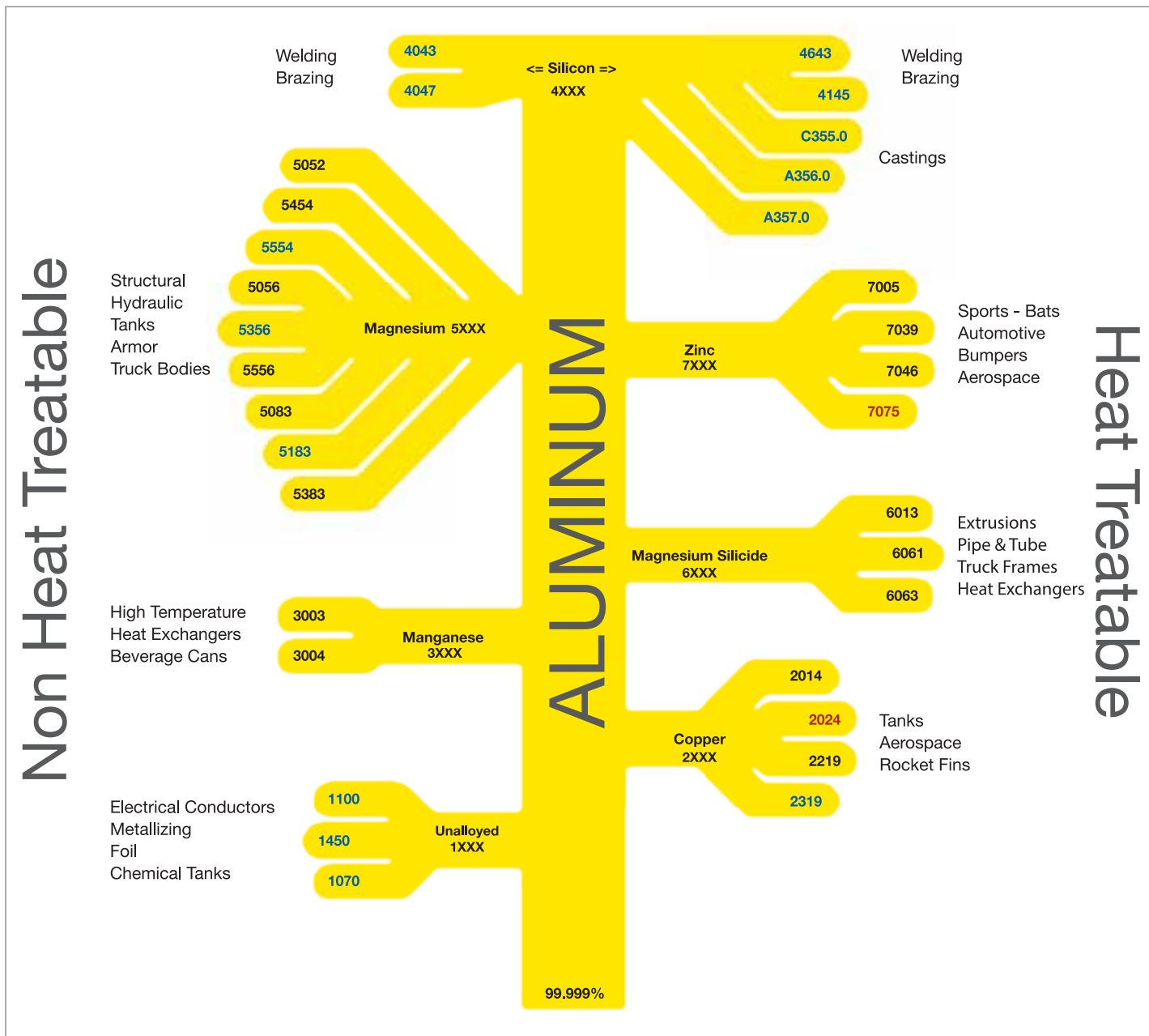

The Aluminum Association uses a four digit numbering system for designating wrought aluminum and wrought aluminum alloys. The image above shows the wrought alloy groups as well as a few examples of common products from each group. The significance of each number is described below.

- 1st Digit – Identifies the major alloying element.
- 2nd Digit – Identifies the rendition of an alloy. For example, 5356 is the 3rd rendition of the original base alloy 5056.
- 3rd and 4th Digits:
  - In the 1XXX group, the last two digits indicate the minimum aluminum percentage. For example, alloy 1188 has a minimum purity of 99.88% aluminum. Alloy 1350 has a minimum purity of 99.50% aluminum.
  - In the 2XXX – 8XXX groups, the last two digits serve merely as counters. For example, 3004 was the next manganese alloyed chemistry after 3003.



## Filler Alloys: Chemical Composition Limits & Physical Properties

Alloy	Silicon	Iron	Copper	Manganese	Magnesium	Chromium	Zinc	Titanium	Others (1)		Aluminum	Approximate Melting Range, °F	Density lbs/in <sup>3</sup>	Post (4) Anodize Color Tint
	Si	Fe	Cu	Mn	Mg	Cr	Z	Ti	Each	Total	Al (min)			
1100	Si + Fe = 0.95		0.05-0.20	0.05	—	—	0.10	—	0.05	0.15	99.00	1190-1215	.098	Golden
1188	0.06	0.06	0.005	0.01	0.01	—	0.03	0.01	0.01	—	99.88	1215-1220	.0975	Clear
1199	0.006	0.006	0.006	0.002	0.006	—	0.006	0.002	0.002	—	99.99	1220	.0975	Clear
1350	0.10	0.40	0.05	0.01	—	0.01	0.05	—	0.03	0.10	99.50	1195-1215	.0975	Clear
206.0	0.10	0.15	4.2-5.0	0.20-0.50	0.15-0.35	—	0.10	0.15-0.30	0.05 (2)	0.15	Rmnd	1060-1200	.101	Golden
2319	0.20	0.30	5.8-6.8	0.20-0.40	0.02	—	0.10	0.10-0.20	0.05 (3)	0.15	Rmnd	1010-1190	.100	Golden
357.0	6.5-7.5	0.15	0.05	0.03	0.45-0.6	—	0.05	0.20	0.05	0.15	Rmnd	1040-1140	.098	Gray
4008	6.5-7.5	0.09	0.05	0.05	0.30-0.45	—	0.05	0.04-0.15	0.05	0.15	Rmnd	1035-1135	.097	Gray
4009	4.5-5.5	0.20	1.0-1.5	0.10	0.45-0.6	—	0.10	0.20	0.05	0.15	Rmnd	1015-1150	.098	Gray
4010	6.5-7.5	0.20	0.20	0.10	0.30-0.45	—	0.10	0.20	0.05	0.15	Rmnd	1035-1135	.097	Gray
4043	4.5-6.0	0.8	0.30	0.05	0.05	—	0.10	0.20	0.05	0.15	Rmnd	1065-1170	.097	Gray
4047	11.0-13.0	0.8	0.30	0.15	0.10	—	0.20	—	0.05	0.15	Rmnd	1070-1080	.096	Gray-Black
4145	9.3-10.7	0.8	3.3-4.7	0.15	0.15	0.15	0.20	—	0.05	0.15	Rmnd	970-1085	.099	Gray-Black
4643	3.6-4.6	0.8	0.10	0.05	0.10-0.30	—	0.10	0.15	0.05	0.15	Rmnd	1065-1175	.097	Gray
5183	0.40	0.40	0.10	0.50-1.0	4.3-5.2	0.05-0.25	0.25	0.15	0.05	0.15	Rmnd	1075-1180	.096	White
5356	0.25	0.40	0.10	0.05-0.20	4.5-5.5	0.05-0.20	0.10	0.06-0.20	0.05	0.15	Rmnd	1060-1175	.096	White
5554	0.25	0.40	0.10	0.50-1.0	2.4-3.0	0.05-0.20	0.25	0.05-0.20	0.05	0.15	Rmnd	1115-1195	.097	White
5556	0.25	0.40	0.10	0.50-1.0	4.7-5.5	0.05-0.20	0.25	0.05-0.20	0.05	0.15	Rmnd	1065-1175	.096	White
5654	Si + Fe = 0.45		0.05	0.01	3.1-3.9	0.15-0.35	0.20	0.05-0.15	0.05	0.15	Rmnd	1100-1190	.096	White
5087	0.25	0.40	0.05	0.7-1.1	4.5-5.2	0.05-0.25	0.25	0.15	0.05 (5)	0.15	Rmnd	1054-1180	.096	White
5754	0.40	0.40	0.10	0.50	2.6-3.6	0.30	0.20	0.15	0.15 (6)	0.15	Rmnd	1095-1195	.097	White

(1) Beryllium shall not exceed 0.0003%

(2) Nickel shall not exceed 0.05%

(3) Vanadium shall be 0.05-0.15% and Zirconium shall be 0.10-0.25%

(4) Use filler alloy chart for color matching

(5) 0.10-0.20 Zr

(6) 0.10-0.6 Mn + Cr

## Conversion Factors

Fraction	Decimal	mm	ft/lb.	m/kg	Approximate Wire Gauge
—	.030	0.8	1215	816	20.5
—	.035	0.9	900	605	19
—	.040	1.0	704	473	18
3/64	.047	1.2	520	349	17
1/16	.062	1.6	290	195	14
—	.071	1.8	220	150	13
—	.079	2.0	172	115	12
3/32	.093	2.4	130	87	11
1/8	.125	3.2	70	47	8
5/32	.156	4.0	45	30	6.5
3/16	.187	4.7	31	21	4.5
1/4	.250	6.3	20	13	2

Convert From	Convert To	Multiply By
inches	millimeters	25.4
millimeters	inches	.03937
square inches	square millimeters	645.2
square millimeters	square inches	.001552
fluid ounces	millimeters	29.57
millimeters	fluid ounces	.03381
ounces	grams	28.35
grams	ounces	.03527
pounds	kilograms	.4536
kilograms	pounds	2.205
Newtons/mm	pounds/inch	145.04
pounds/inch	Newtons/mm	.006895

## Welded Joint Strength

Typically, the as-welded tensile strength of a groove weld is determined by the condition of the heat-affected zone (HAZ) of the base material.

Fillet welds are usually not diluted significantly by the base metal. Therefore, the shear strengths of fillet welds are largely determined by the properties of the filler alloy and not necessarily by the condition of the HAZ of the base.

### Typical Shear Strength - Fillet Welds

Filler Alloy	Longitudinal Shear Strength (KSI)	Transverse Shear Strength (KSI)
1100	7.5	7.5
2319	16.0	18.8
4043	11.5	15.0
4643	13.5	20.0
5183	18.5	28.0
5356	17.0	26.0
5554	15.0	23.0
5556	20.0	30.0
5654	12.0	18.0

Conservative values based on bare minimum fusion. Multiple factors influence shear strength. Contact AlcoTec to discuss your specific application.

### Longitudinal Fillet Weld

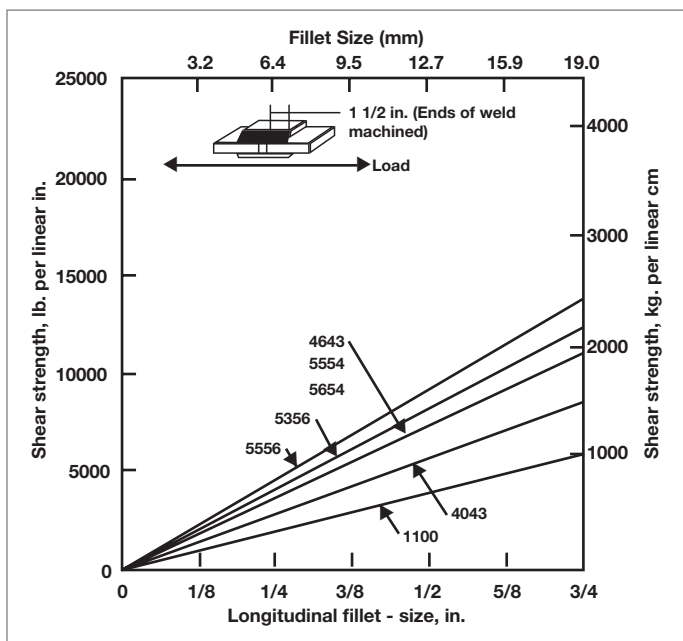

### Transverse Fillet Weld

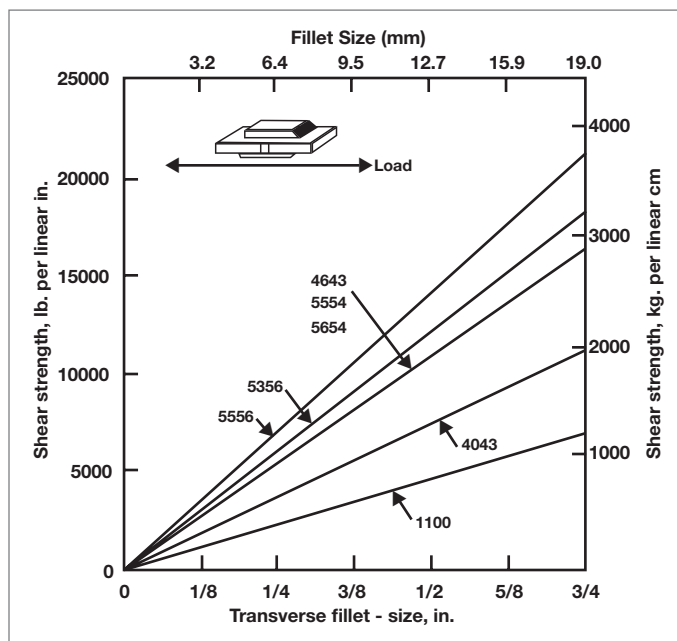

## Typical Tensile Properties - Groove Welds

Base Alloy & Temper	Approximate Melting Range °F of Base Alloy	Base Alloy Properties			Filler Alloy	As Welded Properties			Post-Weld Heat Treated & Aged		
		Tensile Strength psi x 10 <sup>3</sup> (1)	Yield Strength psi x 10 <sup>3</sup> (2)	Elongation % in 2 in.		Tensile Strength psi x 10 <sup>3</sup> (1)	Yield Strength psi x 10 <sup>3</sup> (2)	Elongation % in 2 in.	Tensile Strength psi x 10 <sup>3</sup> (1)	Yield Strength psi x 10 <sup>3</sup> (2)	Elongation % in 2 in.
1060-H16	1195-1215	16	15	8	ER1188	10	5	29	—	—	—
1100-H16	1190-1215	21	20	6	ER1100	13	6	29	—	—	—
1350-H16	1195-1215	18	16	—	ER1188	10	4	29	—	—	—
3003-H34	1190-1210	35	29	9	ER1100	16	7	24	—	—	—
5005-H16	1170-1210	26	25	5	ER5356	16	9	15	—	—	—
5050-H34	1155-1205	28	24	8	ER5356	23	12	18	—	—	—
5052-H32	1125-1200	33	28	12	ER5356	28	14	19	—	—	—
5083-H116	1075-1180	46	33	16	ER5183	43	22	16	—	—	—
5086-H34	1085-1185	47	37	10	ER5356	39	19	17	—	—	—
5154-H34	1100-1190	42	33	13	ER5654	33	18	17	—	—	—
5454-H32	1115-1195	39	30	15	ER5554	35	16	17	—	—	—
5456-H112	1055-1180	45	24	22	ER5556	46	23	14	—	—	—
2014-T6	945-1180	70	60	13	ER4043	34	28	4	50	—	2
2219-T81	1010-1190	66	50	10	ER2319	35	26	3	43 (3)	37 (3) (4)	2 (3) (4)
6061-T4	1080-1205	35	21	22	ER4043	27	18	8	35 (3) (4)	—	8 (3) (4)
6061-T6	1080-1205	45	40	12	ER4043	27	18	8	44 (4)	40	6
6061-T6	1080-1205	45	40	12	ER5356	30	19	11	—	—	—

Typical properties of gas-shielded, arc welded groove joints in aluminum alloys.

(1) Reduced section tensile strength.

(2) 0.2% offset in 2 in. gauge length.

(3) Postweld aged only.

(4) Data assumes sufficient dilution of base.

## Weld Profiles

### Acceptable Weld Profile Criteria per AWS D1.2

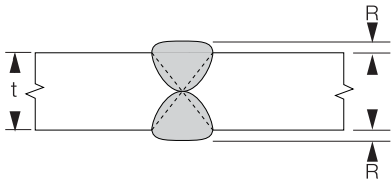
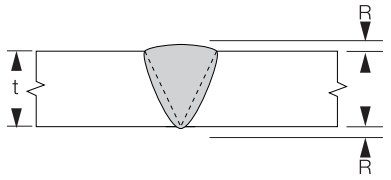
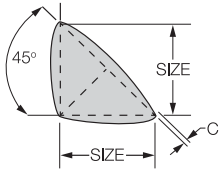
		
<p><u>Base Thickness</u></p> <p><math>T \leq 3/8</math>  <math>3/8 &lt; T \leq 3/4</math>  <math>T &gt; 3/4</math></p>	<p><u>Max Reinforcement</u></p> <p><math>3/32</math>  <math>1/8</math>  <math>3/16</math></p>	<p><u>Width of Weld Face</u></p> <p><math>\leq 5/16</math>  <math>&gt;5/16</math> to <math>&lt;1</math>  <math>\geq 1</math></p> <p><u>Max Convexity</u></p> <p><math>1/16</math>  <math>1/8</math>  <math>3/16</math></p>

### Weld Profile Troubleshooting Guide

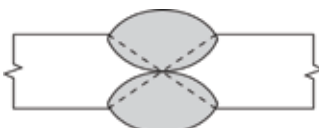
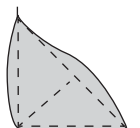
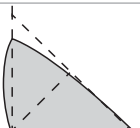
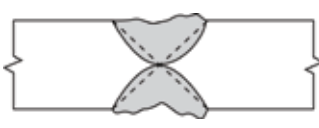
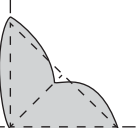
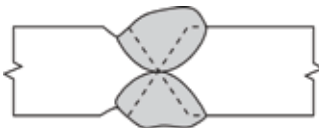
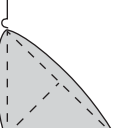
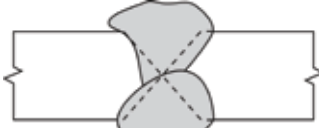
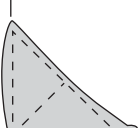
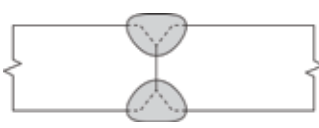
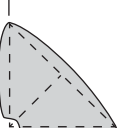
Problem	Example (Groove Weld)	Example (Fillet Weld)	Possible Solution
<p><b>Excessive Convexity/ Reinforcement</b></p> <p>Reduced fatigue strength</p>			<p>Increase arc length</p> <p>Increase torch angle</p> <p>Increase travel speed</p>
<p><b>Insufficient Leg Length</b></p> <p>Reduced mechanical properties</p>	N/A		<p>Change torch angle</p> <p>Change torch position<sup>1</sup></p>
<p><b>Insufficient Throat/Underfill</b></p> <p>Reduced mechanical properties</p>			<p>Reduce cooling rate</p> <p>Increase electrode feed rate</p> <p>Decrease travel speed</p> <p>Decrease arc length</p>
<p><b>Undercut</b></p> <p>Reduced mechanical properties</p>			<p>Change torch position to compensate for:</p> <ul style="list-style-type: none"> <li>Dissimilar section sizes</li> <li>Dissimilar thermal conductivity</li> <li>Out-of-position welds</li> </ul>
<p><b>Overlap</b></p> <p>Severe reduction in fatigue strength</p>			<p>Increase voltage</p> <p>Decrease wire speed</p> <p>Increase travel speed</p>
<p><b>Incomplete Penetration/ Lack of Fusion</b></p> <p>Reduced weld strength and increased sensitivity to crack propagation</p>			<p>Increase amperage</p> <p>Decrease arc length</p> <p>Decrease torch forehand angle</p> <p>Increase travel speed</p>

(1) For example, the thermal conductivity of 5083 is 32% less than that of 6061 because of the higher magnesium content. This requires more heat input into the 6061 alloy.

## Weld Control Characteristics

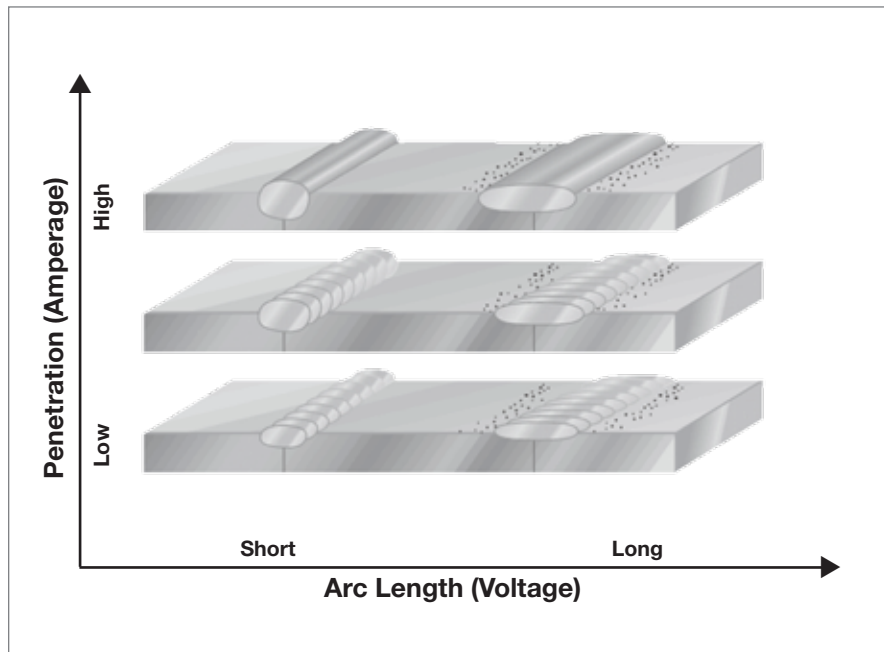

Recommendations	
Root Pass	Shorter Arc
Finish Pass	Longer Arc
5XXX Alloys	Shorter Arc Lower Arc Voltage Higher Amperage
4XXX Alloys	Longer Arc Higher Arc Voltage Lower Amperage

## Parameter Changes & Current Density

Increasing arc voltage decreases:

- Wire to work piece gap
- Energy distribution width

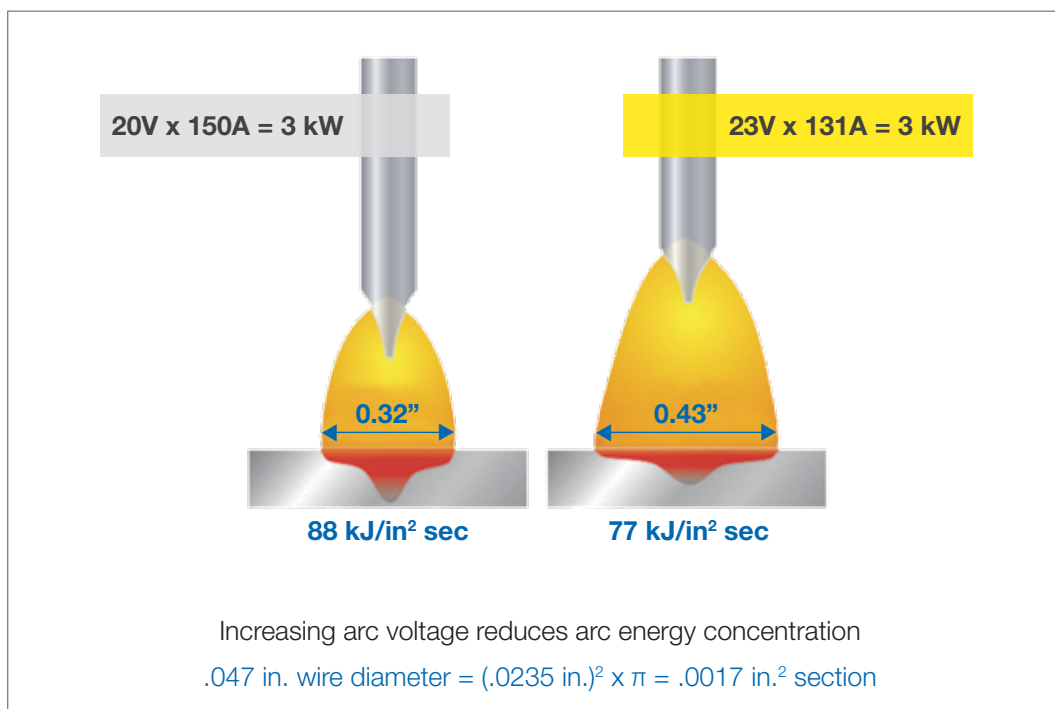



## Backing Bars

### What is the best backing bar material for an aluminum groove weld?

There really isn't a "best" material for a backing bar. To determine the most appropriate material, you must consider a few things:

### Is the backing bar going to be permanent or temporary?

For a permanent backing bar the answer is easy – use the same alloy as one of the groove weld components.

For temporary bars, consider these points:

- Hard-coat anodized aluminum, copper, stainless steel, and ceramic can all be used.
- Don't weld directly on the backing material. A temporary bar is there only to support the root reinforcement. Elements from the backing material may contaminate the weld.
- Hard-coat anodized aluminum works very well. The thermal properties are the same as the base material and the groove is easily machined.
- Copper has a tendency to cool the weld more quickly than the other materials (copper cools quickly).
- Stainless Steel has a tendency to heat up and cool the weld more slowly (stainless cools slowly).
- Ceramic is available with adhesive for attaching directly to the base material, but is also very fragile.

### Should the groove be square or rounded in a temporary backing bar?

Typically, a square cut groove is going to provide better results than a rounded (or bowl shaped) groove. The images below show the result of a square cut in the temporary backing bar, the joint design, and the cross section of the weld achieved.



1 Pass - 1.6 mm 5356 - approximately 22 ipm travel speed  
23.0 V; 342 ipm wire feed speed

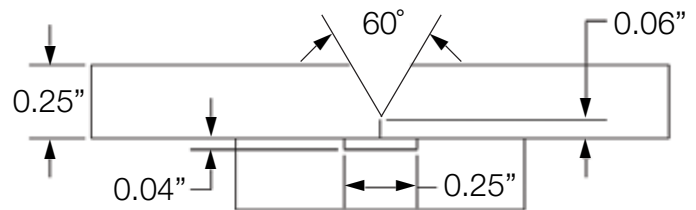

## Bend Testing Aluminum

When conducting bend tests, care must be taken to ensure the proper bending criteria are used. The following steps should be taken to help ensure accurate bend test results.

1. Ensure proper test jig is used:

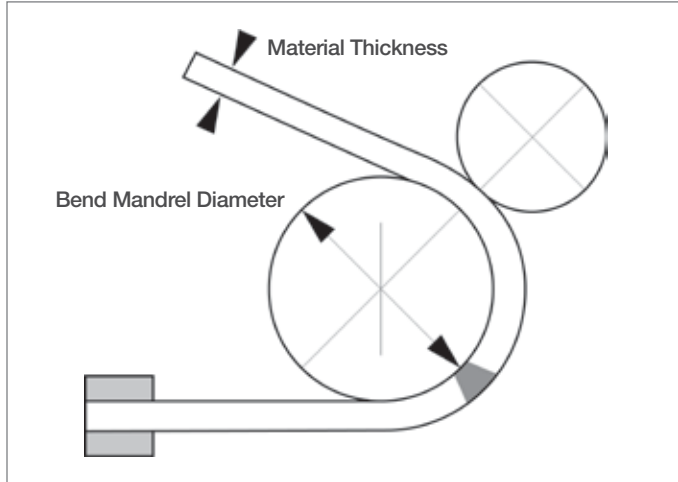

**Wrap-Around Guided Bend Jig  
(Preferred for Aluminum)**

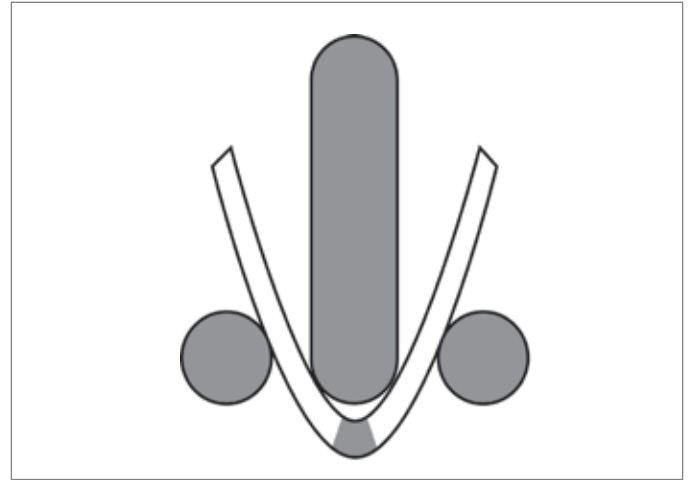

**Plunger-Style Test Jig  
(Not Recommended for Aluminum)**

2. Review applicable code/specification to ensure the proper bend radius is used. Also note that this is where the base and filler alloy combination affects the bend radius and sample thickness.

### Excerpt from AWS D1.2: 2014

Thickness of Specimen	Bend Mandrel Diameter	Materials
3/8 t	1-1/2 4t	M21 and M22
1/8 t (<1/8)	2-1/16 16-1/2t	M23* or F23 Welds
3/8 t	2-1/2 6-2/3t	M25 and Annealed M23*

*\*Note: Temper condition can also have an influence on the testing criteria.*

3. Ensure samples are prepared properly, according to the applicable code/specification, prior to bending.

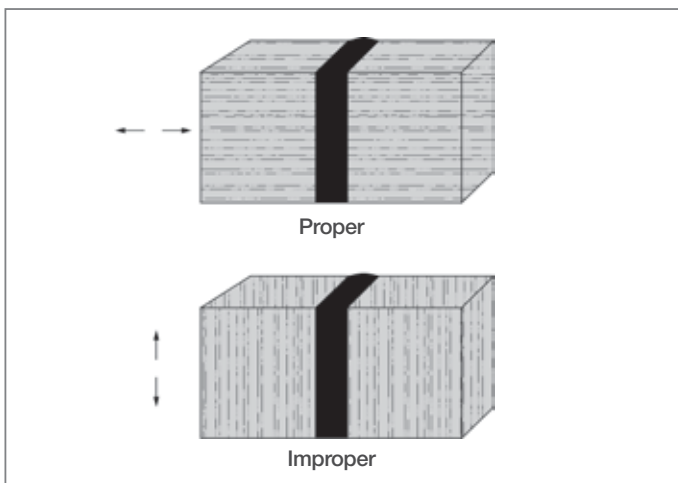

**Sanding lines should be perpendicular to the weld  
(in-line with the bending direction)**

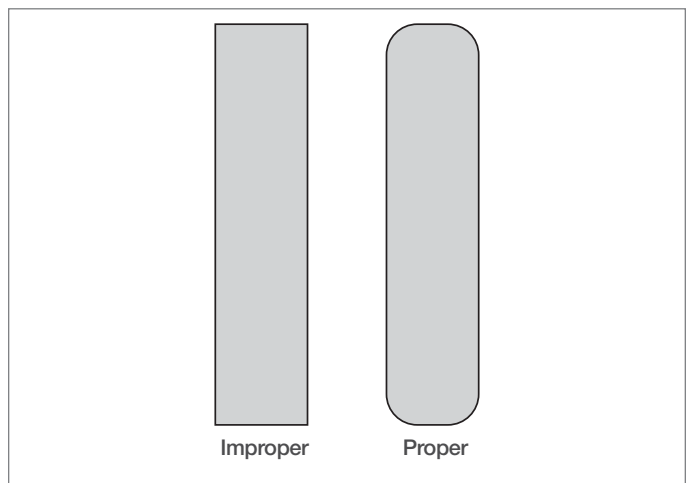

**A radius should be applied to the edges of each bend  
specimen per applicable specification**

## Atmospheric Conditions Affect Weld Quality

Many fabricators experience welding problems at different times of the year. Moisture (H<sub>2</sub>O) is a prime source of hydrogen. At arc temperatures, water breaks down releasing hydrogen atoms that cause porosity in weldments. Shielding gas supplies are controlled to very low moisture content (-70°F dewpoint or lower). Likewise, the atmospheric conditions in a fabricating facility need to be controlled to prevent moisture condensation from forming on electrode or base metal.

### Relative Humidity vs. Dew Point

Relative Humidity %	Δt °F Air-Metal	Δt °C Air-Metal
87	3.6	1.1
75	7.2	2.2
66	10.8	3.3
57	14.4	4.4
50	18.0	5.5
44	21.6	6.6
38	25.2	7.7
34	28.8	8.8
30	32.4	9.9
26	36.0	11.0
23	39.6	11.9
21	43.2	13.2
18	46.8	14.3
16	50.4	15.4

*Example: If the relative humidity in the weld area is 75%, the base metal and electrode must be no colder than 7.2°F below the air temperature to prevent moisture condensation.*

### Possible Solutions

1. Bring material into work space 24 hours prior to usage. This allows the temperatures to stabilize.
2. Store filler material in an oven.
3. Store base material vertically allowing air flow to help the material temperature to stabilize.

## Feedability

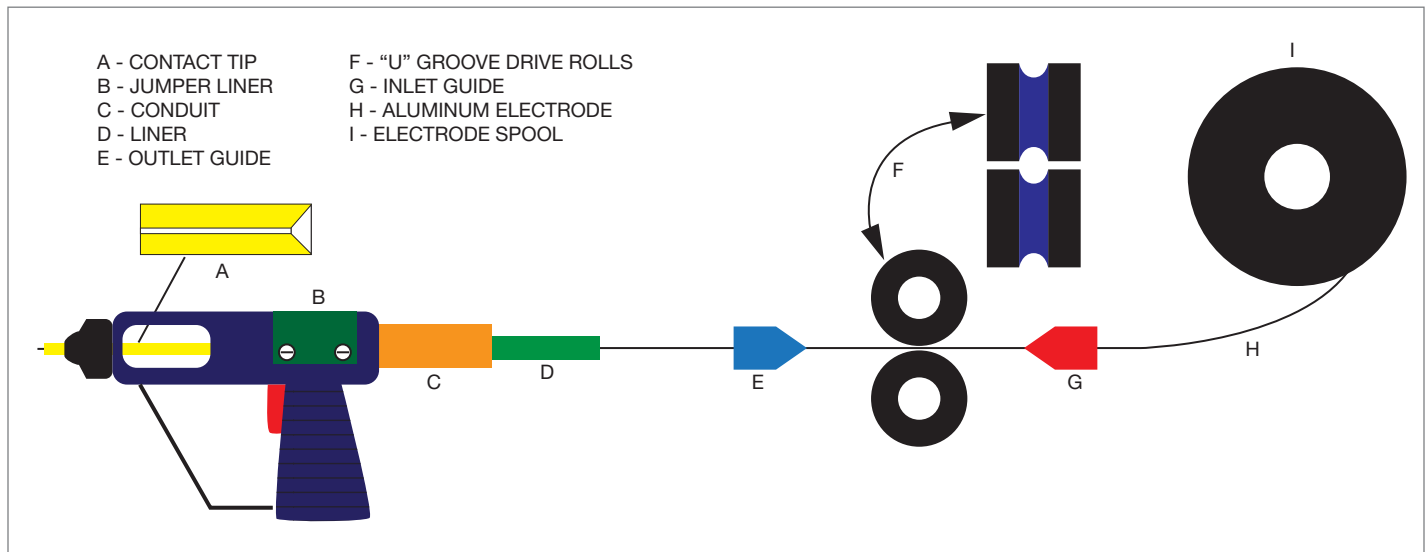

Aluminum welding equipment demands attention to detail as feedability affects performance and productivity. Below are areas of concern that can improve feedability, reduce downtime, and minimize maintenance costs.

### Correct Contact Tip Size (I.D. and length)

- I.D. 10% larger for hard wire
- I.D. 20% larger for soft wire
- Longer is better
- Remove burrs from tip entrance
- Polish, clean, and inspect contact tips<sup>1</sup>
- Do not bend or crimp tips

### Gun Liners and Wire Guides

- Teflon is soft and can hold embedded particles
- Nylon is tough, holds its shape and reduces embedded particles
- Right size liner
- Cut to the proper length
- Plastic guides such as Nylon work to reduce shavings

### Torch and Nozzles

- Straight nozzles aspirate less air than tapered
- Water-cooled torches are more efficient
- Curved torches require more drive force
- Overheated torches can melt liners and ruin parts
- Aluminum and argon lower the duty cycle of torches (for torches rated with low voltage and CO<sub>2</sub> gas)
- Push/pull for whip lengths over 9 ft. (3 m)
- Slave in the rear push/pull reduces liner wear and feeding issues

### Drive Rolls

- U-groove type reduces shavings
- Clean and polish rolls regularly<sup>2</sup>
- Inspect for sharp edges, embedded particles, and misalignment
- If V-groove are used on one side, use a flat on the other
- V-grooves rollers with an angle > 60 degrees
- Plastic rolls can wear unevenly causing wire distortion

(1) AlcoTec offers a contact tip polishing kit (part no. TIP-TUBE)

(2) AlcoTec offers a drive roll polishing kit (part no. DRV-ROLLPOLISH)

## Excessive Face Reinforcement

Welders completing groove welds often end up with excessive face reinforcement on their welds. Whether they just want to make sure the joint is filled in or they think it makes the weldment “stronger”, it typically causes more potential for harm than good. Excessive face reinforcement on a groove weld will typically create a larger stress riser which may increase the odds of the weldment cracking because of fatigue. Note the location of the crack in the weld image below.

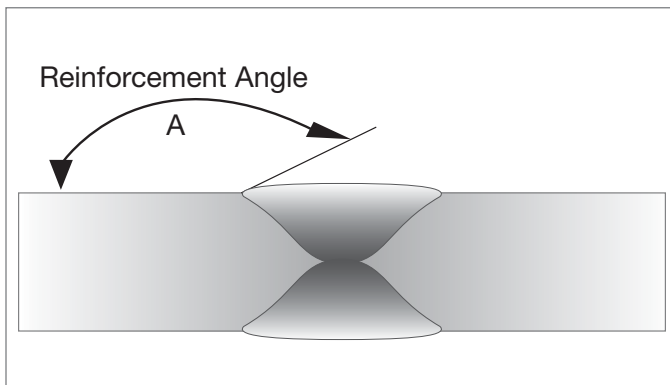
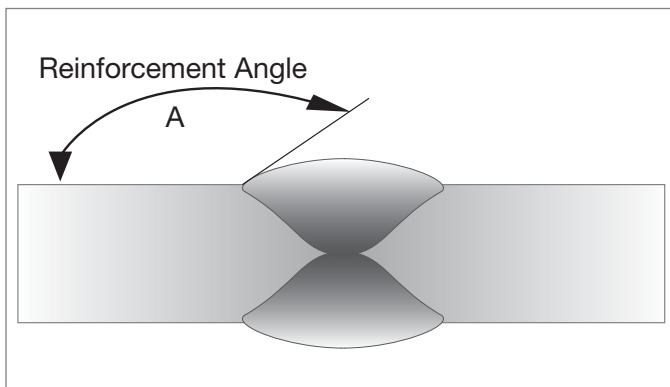
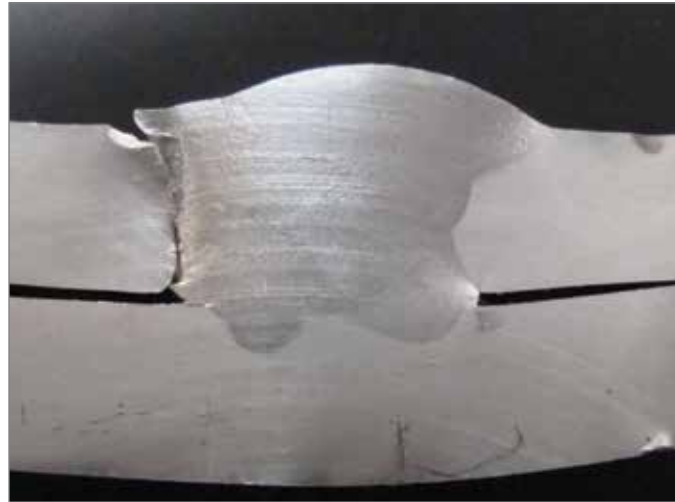

Angle “A” Degrees	Maximum Stress (3 Million Cycles) ksi (MPa)
100	7.5 (52)
130	9.5 (66)
160	13.5 (93)

By increasing the reinforcement angle of the weld metal as shown in these images, the maximum amount of stress the assembly could withstand almost doubled.

Additionally, removal of the reinforcement can restore fatigue performance to near un-welded condition in non heat-treatable alloys or re-heat-treated surfaces.



## Dilution

A weld essentially becomes a new alloy made up of the base and filler alloys. Dilution is the amount of base alloy that mixes with the filler alloy to create the new weld alloy. There are multiple factors that affect the amount of base dilution into the weld puddle. Although the welding parameters can change the dilution ratio, the easiest way to actually control it is by modifying the joint design (see images below).

### Dilution Ratios of Joints

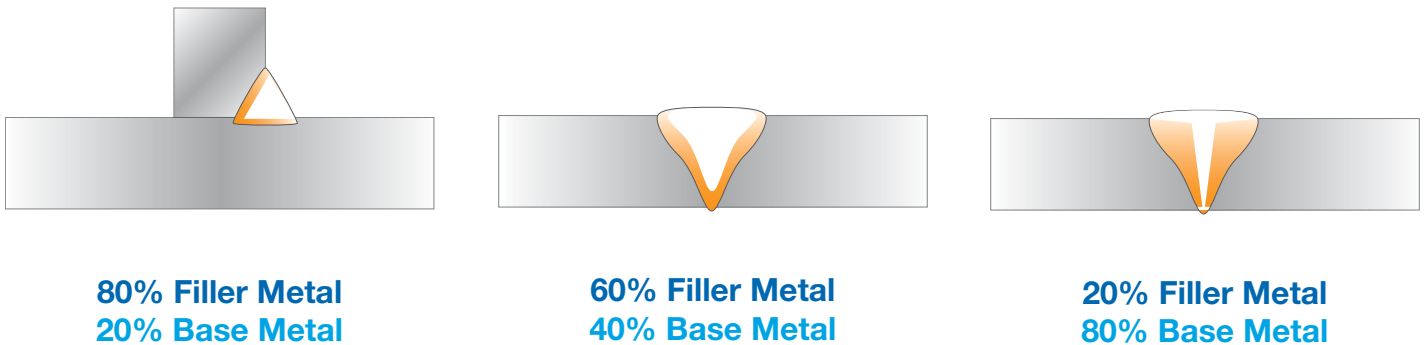

Depending on the alloys involved, simply changing the joint design may be enough to change the tensile strength of an as-welded groove assembly. The image below shows the theoretical difference in dilution ratios by modifying the joint design from a square butt to a single V-groove. The amount of base metal that is diluting the filler alloy is reduced in the single V, making the overall magnesium content of the new weld alloy significantly higher.

Depending on the other variables involved, this may be all that is needed to go from just missing the minimum tensile strength to achieving it regularly (and with room to spare). Another benefit of reducing the amount of base metal dilution is that the probability of stress cracking is typically reduced.

### Weld Composition: Dilution Effect

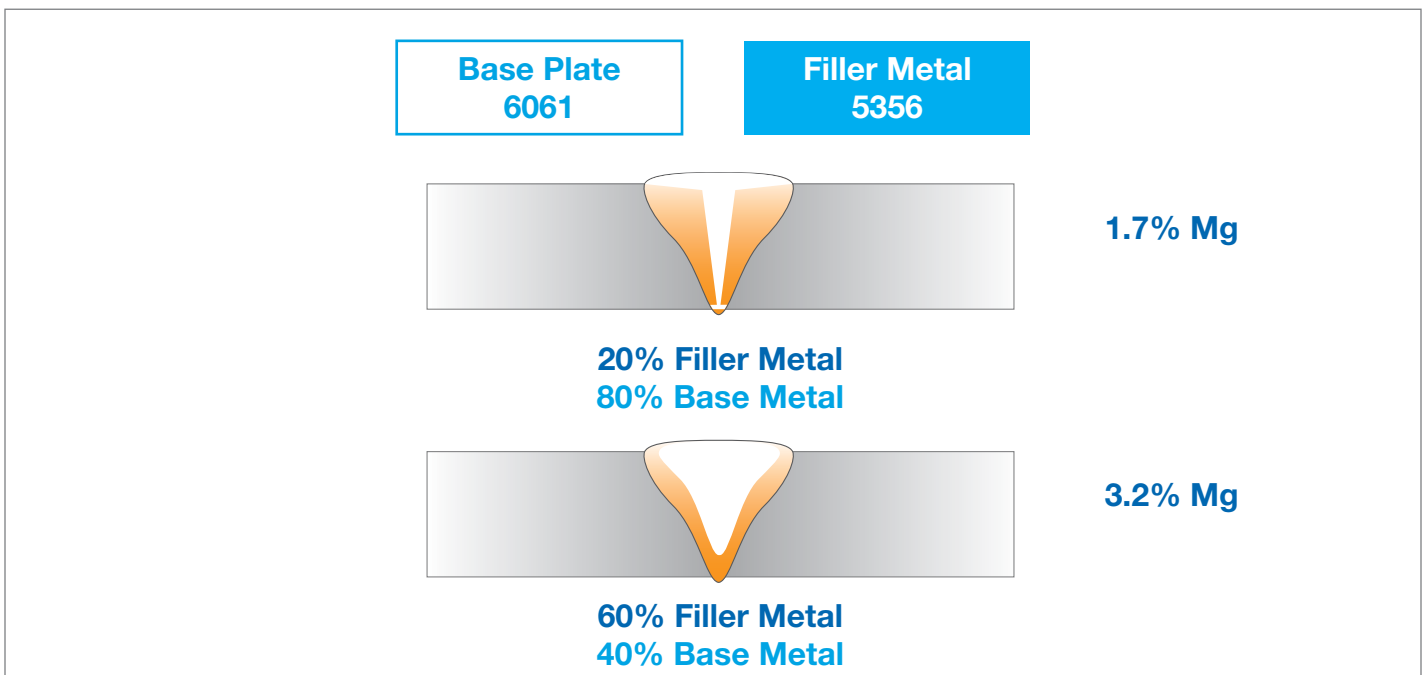

## Aluminum Alloys

Aluminum can be alloyed with several other elements such as copper, magnesium, manganese, zinc, and silicon. Each of these can be added alone or in combinations for various considerations such as strength, fluidity, corrosion resistance, and ductility.

Working with aluminum is much like working with wood. Most power tools using carbide blades are suitable for cutting and prepping joints for welding. These will remove metal quickly and will not leave a residue behind like grinding pads and stone cutting wheels. The chips left behind contain most of the heat from the cut, and therefore, coolants or other lubricants are not needed.

Once the cut is made, the surface should be as clean as possible. Carbide router bits also work well for joint preparation where rounded edges are preferred as they take heat better than sharp edges, which can result in oxides.

Do	Do Not
Use carbide bits and blades	Use lubricants (cut dry)
Use higher speeds for cutting and prepping	Use oxy-fuel to cut aluminum
Use band saws with 3 to 4 teeth/in.	Carbon arc gouge
Remove plasma and laser cuts (1/8 in.)	Use power wire brushes with excessive pressure (smears aluminum)
Clean surfaces before wire brushing	Direct air tool exhaust toward weld joint

### Avoid Plasma/Laser Cut Micro Cracks in Welds



**Micro-cracks** are potential crack starters in aluminum welds.

For heat treatable aluminum alloys, 1/8 in. (3 mm) of material shall be removed by machining from plasma arc and laser cut edges that will be welded. - AWS D1.2

## Heat-Treatable and Non Heat-Treatable Alloys & the Heat Affected Zone (HAZ)

Aluminum alloys can be separated into one of two groups, **heat-treatable** and **non heat-treatable**. All aluminum alloys can be strengthened through cold working operations, but only the heat-treatable alloys can be strengthened through thermal processes. Because of this characteristic, the heat from arc welding processes affects each group differently.

Most aluminum alloys are annealed to their softest condition when they reach approximately 650°F (350°C). Considering that aluminum melts somewhere in the area of 1100-1200°F (600-650°C) it can be expected that portions of the Heat Affected Zone (HAZ) will reach the annealing temperature during an arc welding process. This results in the weld assembly enduring a thermal cycle that can greatly change the properties of the weldment.

The completed weld assembly can be broken up into three distinct areas:

1. Weld Metal
2. Heat Affected Zone (HAZ) adjacent to the weld
3. Base material beyond the HAZ which has been unaffected by the welding operation.

### Heat Treatable

All of the 2XXX, 6XXX, 7XXX, and a few of the 4XXX series alloys are heat-treatable. This means that these alloys can be strengthened, not only through cold working, but also through thermal processes.

In the case of the heat-treatable alloys, the heat affected zone presents some interesting dynamics. Although the HAZ will see the annealing temperature during the arc welding process, it is often not fully annealed. As a result of the rate at which the assembly cools, a partial heat treatment typically occurs, which generally results in tensile strengths slightly higher than the annealed strength of the alloy.

However, the strength of the HAZ can also be negatively affected by the amount of time it spends at the elevated temperatures encountered during arc welding. This is the "time at temperature" relationship, which drives the resultant strength of the weldment. The longer the weldment is at elevated temperatures, the weaker the HAZ is typically expected to be. This "overheating" phenomenon can actually result in a groove weld tensile strength below the minimum required.

### Non Heat-Treatable

This group includes all of the 1XXX, 3XXX, 5XXX, and the remainder of the 4XXX series alloys. These alloys can only be strengthened through strain hardening. Thermal treatments cannot be used to strengthen these aluminum alloys.

The heating of the HAZ, which takes place during the arc welding operation, is sufficient to anneal the base material within the HAZ area, and return it to the alloy's softest condition. Unlike the heat-treatable alloys, non heat-treatable alloys do not generally require extended amounts of time at elevated temperatures to become annealed.

Annealing eliminates the strain hardening as well as the microstructure that is developed as a result of cold working. For this reason, the minimum tensile strength requirements for as-welded non heat-treatable alloys, regardless of the original work hardened temper, is based on the annealed strength of the base alloy.

### Non-Weldable Alloys

There are also a few heat-treatable alloys, which are considered to be "non-weldable". It is not that they cannot be welded, but that they should not be welded if there is ANY LIABILITY involved with the finished product. Due to the chemistries of these alloys, arc welding temperatures produce a microstructure that will lead to grain boundary cracking and there is nothing that can be done to prevent it. The two most common alloys in this group are 2024 and 7075, but there are many others.

### Summary

When designed and welded properly, the tensile strength of a groove weld will be determined by the HAZ. While the heat from the arc welding process will affect both groups of alloys, the reduction in strength in the HAZ will be fairly predictable in the non heat-treatable alloys. Since the heat-treatable alloys respond uniquely to the heat, the resulting HAZ strength can be less predictable. In order to obtain consistent results, the use of qualified weld procedures is highly recommended.

# Considerations When Repairing Aluminum Structures

## Identification of the Base Alloy

Probably the most important, and usually the first step in the repair operation, is identifying the aluminum base alloy being repaired. If the base alloy type is unknown, one could contact the original manufacturer of the component to establish the aluminum base material type. If the base material type is not available through a reliable source, it is impossible to select a suitable welding procedure.

There are many different types of aluminum alloys, some have very good weldability and others have extremely poor weldability. Unfortunately, if the base material type is not known, or unavailable, chemical analysis is the only one reliable way of establishing the exact type of aluminum alloy. A small sample of the base material must be sent to a reliable aluminum-testing laboratory, and a chemical analysis must be performed. Generally, the chemistry can then be evaluated and a determination as to the most suitable filler alloy and the welding procedure can be made.

## Cleaning and Material Preparation Prior to Welding

It is very important to clean the repair area completely prior to performing the weld repair. This is typically achieved using a degreasing solvent to remove hydrocarbons followed by stainless steel brushing to remove the aluminum oxide. More aggressive filing, or chemical cleaning, may be required for some applications.

In situations where it is necessary to remove existing weld or base material in order to conduct the repair, you need to consider the methods available to perform this operation as well as their effect on the finished weld. If you need to remove a crack in the surface of a weld prior to re-welding, you must use a method that will not contaminate the base material to be welded. Care should be taken when using grinding discs as some have been found to contaminate the base material by depositing particles into the surface of the aluminum. Routing and chipping with carbide tools is often found to be a successful method of material removal.

## Base Material Strength Reduction After Welding

There may be considerations relating to the effect of the heating of the base material during the repair welding process. Aluminum alloys are divided into two groups:

1. Heat-treatable
2. Non heat-treatable

Typically, the non heat-treatable alloys are used in a strain-hardened condition and the heat-treatable alloys are usually used in one heat-treated form or another. During the welding process, the heat introduced to the aluminum base will generally reduce the strength of the base material in the heat-affected zone (HAZ).



*Cracked repair weld due to improperly preparing the repair area.*

The amount of reduction in strength and the size of the area affected is dependent on the original condition of the base material prior to welding and the temperature and time at temperature of the base material during welding. The as-welded strength, as opposed to the original base material strength, may need to be considered after welding.

## Repairing High Performance Aluminum Alloys

Another consideration associated with the repair of a small group of aluminum structures is the temptation to repair high performance, typically high replacement priced components, made from specialty aluminum alloys.

These materials are often found on aircraft, hand gliders, sporting equipment, and other types of high performance, safety-critical equipment, and are not usually welded on the original component. There are a small number of high-performance aluminum alloys that are generally recognized as being un-weldable.

## Summary

There are many considerations associated with the successful repair of aluminum alloys. Most important is to understand the many different aluminum alloys and that they all require individual consideration. The majority of the base materials used for general structural applications can be readily repaired using the correct welding procedure. The majority of welded aluminum structures are designed to be used in the as-welded condition and, therefore, with the correct consideration, repair work of previously welded components can be conducted satisfactorily.

## Shielding Gas for Arc Welding Aluminum

### Shielding Gas Functions

- Provides a plasma for commutation of current
- Protects the weld pool from reaction with air environment
- Provides cleaning action, which partially removes the aluminum oxide from the base material (DCEP)

### Properties of Shielding Gases

Argon	Helium
<b>Advantages</b>	
Good arc initiation and stability	Higher arc voltage
More effective shielding	Broad weld root width
Lower cost	Reduced porosity
Good cleaning	
<b>Disadvantages</b>	
Narrow weld root width	Poor cleaning
	Poor arc initiation and stability
	Higher cost
	Higher flow rates required

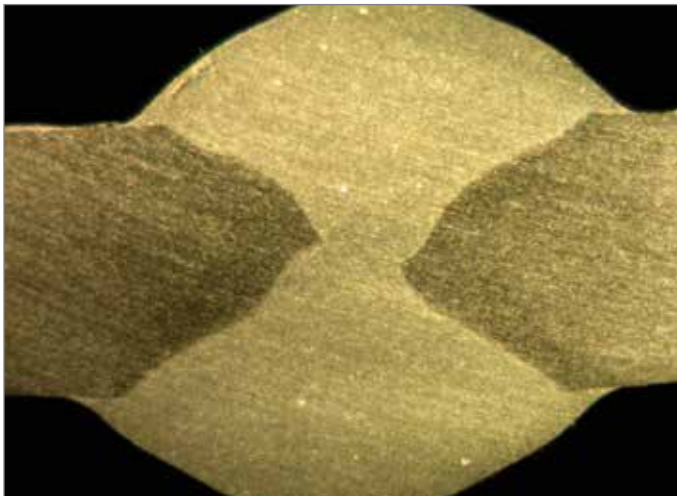

Argon

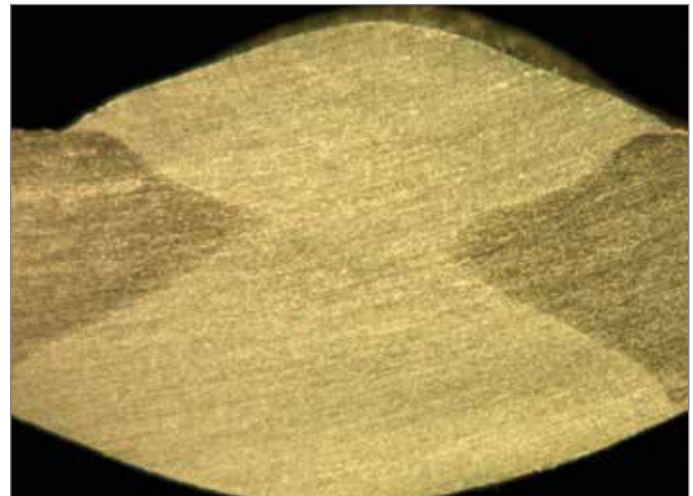

Helium



## Easy Weld Quality Tests

**Lack of fusion and porosity** can be considered the two most common discontinuities in aluminum welds. If you're making changes to your process to reduce these items, you'll want to be able to check your weld quality right away. Below are a few methods you can use for quick weld quality checks.

### Fillet Welds

You can easily check fillet welds for both lack of fusion and porosity using the fillet fold over test. Weld one side only of a tee joint and then fold the weldment over as shown here. If the weld breaks, examine the internal structure of the weld metal (examples are shown below).

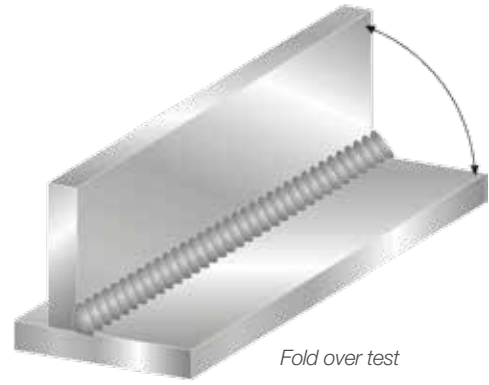

*Porosity will show up as very shiny, spherical inclusions.*



*Lack of fusion is evident when the sharp edge of the vertical component can still be seen under the weld metal.*



*When complete fusion is achieved, the edge of the vertical component will be melted away by the weld metal.*

## Easy Weld Quality Tests

An easy way to examine the cross-sectional profile of a weld is to perform a “poor-man’s etch”. This can be done on fillet and groove welds. It involves cutting the weldment to expose the cross section and polishing it as smoothly as possible. Then warm up the sample (warm to the touch is sufficient) and spray the face to be etched with Easy Off® oven cleaner. The chemical in this cleaner (sodium hydroxide) will etch the surface after about 20-30 seconds. Rinse the sample, dry it (compressed air cans work nicely), and then dust it with a clear lacquer.



**Complete Fusion**

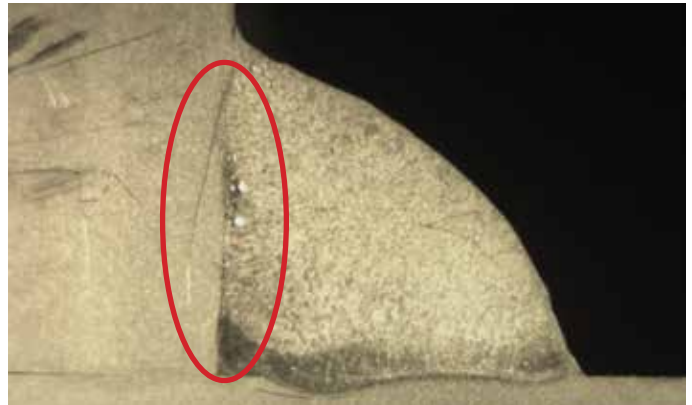

**Lack of Fusion**

### Groove Welds

Since groove welds cannot simply be folded over, a nick-break procedure can be done to examine the internal weld structure.

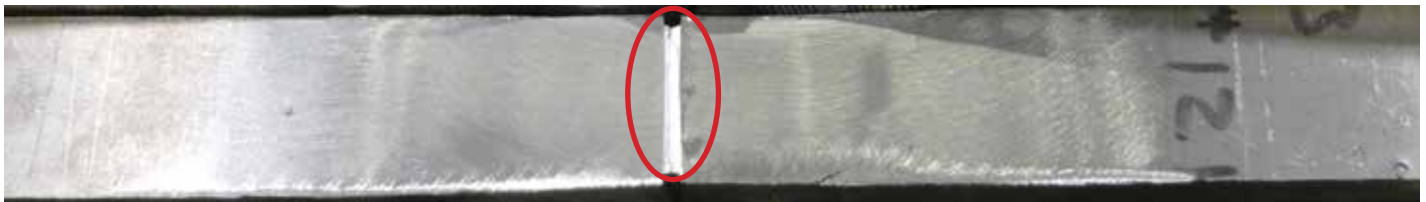

Use a saw to notch each side of a sample taken from a groove weld assembly, as shown.



Clamp one end in a vice and strike the other end with a hammer to break the sample.

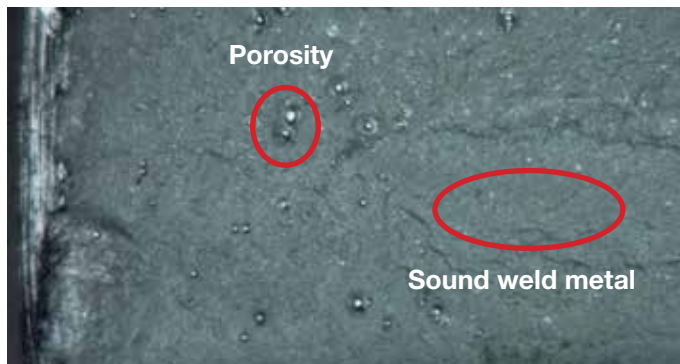

## Weld Cracking

### Common Causes and Cures

There are two types of cracks that can occur in aluminum welds: **stress cracks and hot cracks**.

**Stress cracks** occur when the weld is simply unable to withstand the forces applied to it. This can be due to a poor joint design that is welded as designed, a weld that is just not strong enough for the application (not designed properly) or an improper weld. Images 1A and 1B show fillet weld examples. Image 1A shows the profile of an acceptable weld. Image 1B shows an excessively concave weld that failed through the effective throat (refer to Image 2). If the weld is inadequate for any of the above mentioned reasons, it is very possible it will not withstand service conditions.

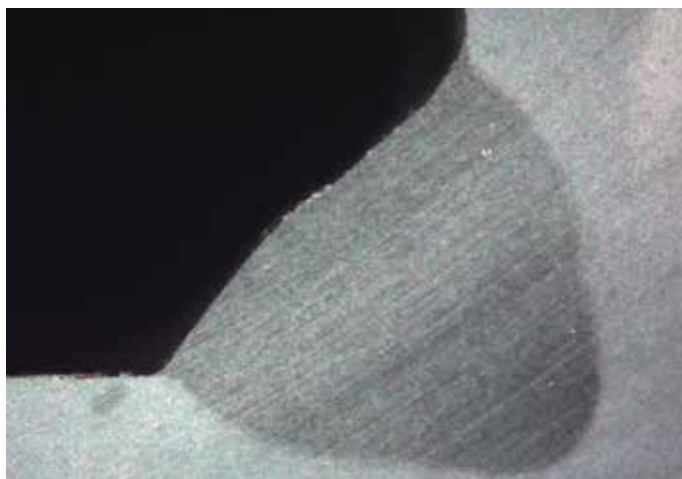

Image 1A

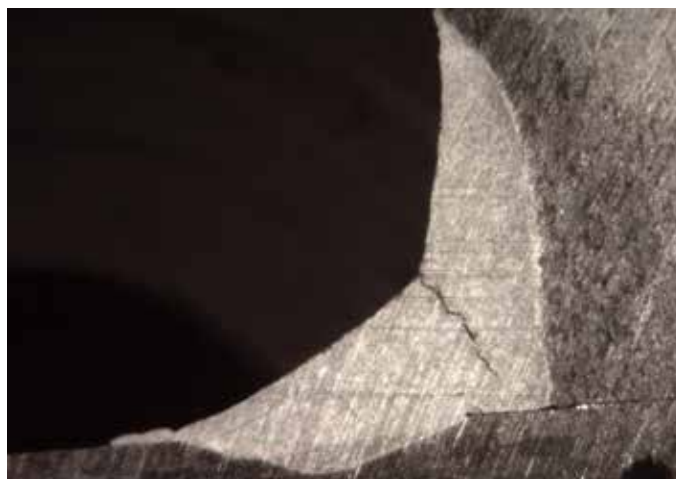

Image 1B

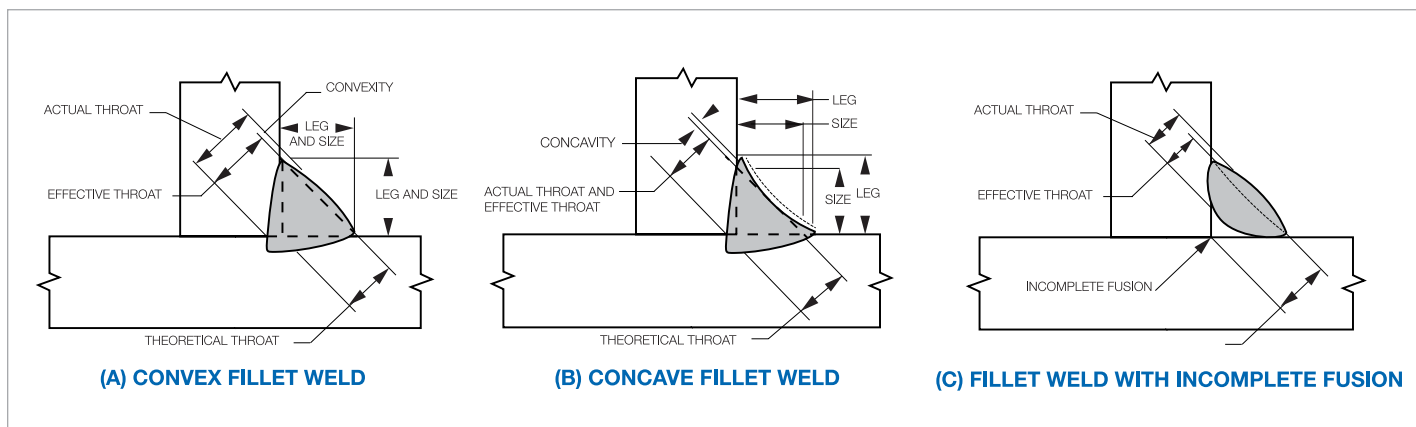
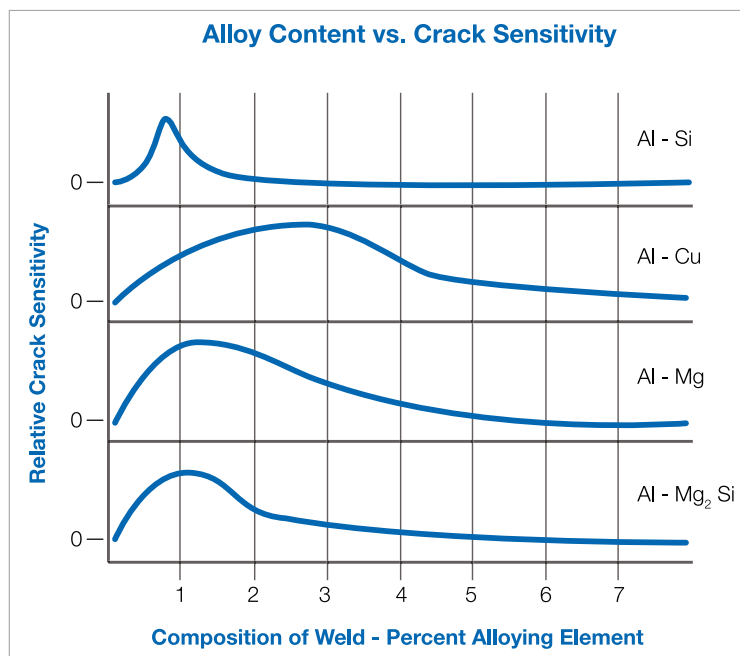

Image 2

**Hot cracks** are a result of the chemistry. It can be the chemistry of the base alloy, the filler alloy or the combination making the weld itself. The graph that follows shows the hot cracking sensitivity for some of the most common aluminum alloy groups; Silicon (4XXX), Copper (2XXX), Magnesium (5XXX), and Magnesium-Silicide (6XXX).

## Weld Cracking



Different alloying elements affect the melting temperatures and ranges of aluminum. Alloys with a larger liquid to solid range will have a greater tendency to hot crack. The graph shows where each chemistry's peak of crack sensitivity will be based on the percentage of the major alloying element.

**Crater cracks** may occur as a result of stress and/or chemistry. Crater cracks that are caused by stress typically occur when the weld termination point (crater) has a smaller cross section than the rest of the weld and simply cannot withstand the forces applied during the solidification process (see Images 3A and 3B).

Because of their chemistry, some base materials are more susceptible to hot cracking than others. Welds made on these alloys need to be "flooded" with enough of the filler alloy to change the chemistry and move it away from the crack sensitive range. Since the crater is typically smaller in cross-section, there is often not enough filler alloy added to change the weld pool chemistry and it becomes prone to hot cracking, even though the remainder of the weld is not.



Image 3A



Image 3B

Since weld cracks can be the result of stress, chemistry, or a combination, determining the root cause can be difficult. For assistance in troubleshooting weld cracking concerns, please contact AlcoTec Technical Services at 1-800-228-0750.

## Performance Improvement - Increasing Wire Diameter

### What affect does increasing wire diameter have on the welding process?

Some advantages of increasing wire diameter are: better fusion/penetration, increased travel speeds, higher deposition rates, lower price per pound, and better feedability.

Due to the physical and mechanical properties of aluminum, it is very feasible to increase wire diameter and either: 1) go faster to increase production rates or, 2) make a larger weld without slowing down. The tables below show the results from using larger wire for each goal. The table layout shows the percent increase between each wire increment as well as the increase if you were to “skip” a level.

### Common Bead Width

Diameter (in.):	.047	.062	.071	.094
Amps	223	274	319	375
Volts	22.5	23	24	25
Wire Feed Speed (ipm)	523	366	295	180
Bead Width Target (in.)	0.45	0.45	0.45	0.45
Travel Speed (ipm)	26	35.8	42	49
Percent Increase in Travel Speed	—	37.7	17.3	16.7
	—	—	61.5	36.9
	—	—	—	88.5

### Common Travel Speed

Diameter (in.):	.047	.062	.071	.094
Amps	225	258	264	375
Volts	23	23	23	26
Wire Feed Speed (ipm)	531	366	271	180
Travel Speed (ipm)	27	27	27	27
Bead Width (in.)	0.422	0.480	0.582	0.688
Percent Increase in Travel Speed	—	13.7	21.3	18.1
	—	—	37.9	43.2
	—	—	—	62.9

This is just one step toward improving performance and productivity. Other tools and techniques can be found throughout this guide.



## Filler Alloy for Welding 6061-T6

One of the most frequently asked aluminum welding questions is “What filler alloy do I use for welding 6061?”. The AlcoTec filler alloy chart has several suggested options of filler alloys to use with 6061. From a chemistry stand point, there are very few options that are not acceptable. However, there are a few elements to consider when choosing the most appropriate filler alloy to use.

1. **Ease of welding** - this is the relative freedom from weld cracking. By use of hot cracking sensitivity curves (see page 25) for the various aluminum alloys, and through the consideration of dilution between filler alloy and base alloy, we can establish the filler alloy/base alloy crack sensitivity rating.
2. **Strength of welded joint** - consideration of the tensile strength of groove welds and shear strength of fillet welds, when welded with different filler alloys, can prove to be extremely important during welding design. Different filler alloys, which may exceed the as-welded tensile strength of the base material, can be significantly different in shear strength performance.
3. **Ductility** - a consideration if forming operations are to be used during fabrication, and may also be a design consideration of service if fatigue and/or shock loading are of importance.
4. **Corrosion resistance** - a consideration for some environmental conditions and are typically based on exposure to fresh and salt water.
5. **Sustained temperature services** - the reaction of some filler alloys at sustained elevated temperature (above 150°F). This may promote premature component failure due to stress corrosion cracking.
6. **Color match** - base alloy and filler alloy color match after anodizing can be of major concern in some cosmetic applications.
7. **Post weld heat treatment** - the ability of the filler alloy to respond to post weld heat treatment associated with filler alloy chemistry and joint design.

These are all elements that must be considered when selecting a filler alloy for welding on 6061. It is the application of the completed weldment that will drive which alloy should be used for welding.

### Color Match After Clear Anodize

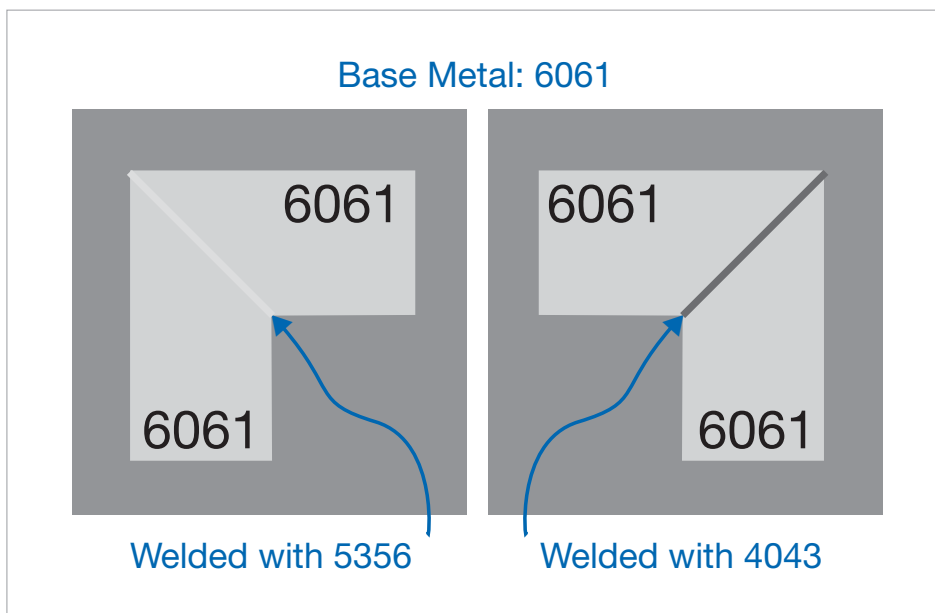

## The Affect of Texture on Anodizing

What if you have welded a base material with a filler alloy that has an “A” rating for color match, but can still see the weld? When a part is anodized, the oxide layer that is added follows the contour of the part, it does not fill in the valleys to make a level surface. It is not possible to see the actual surface texture without the aid of magnification, but when the light reflects off of the base material, you will see the difference.

The image below shows how the light will pass through the anodized layer and then reflect back through it - this is where the perceived color match comes from. Wrought products have very smooth surfaces where cast products do not. When a rolled or extruded product (wrought) is welded, the weld is actually a cast structure. Since the textures are now different, the light will reflect differently and the weld will still be “visible” even though it is the same color.

Therefore, to make the weld as close to “invisible” as possible, you can add a texture to the entire surface. This can be done using a variety of methods (bead blasting, sand blasting, sanding, etc.).

## Color Matching

Accomplished by selecting proper filler alloy and altering surface of the part.

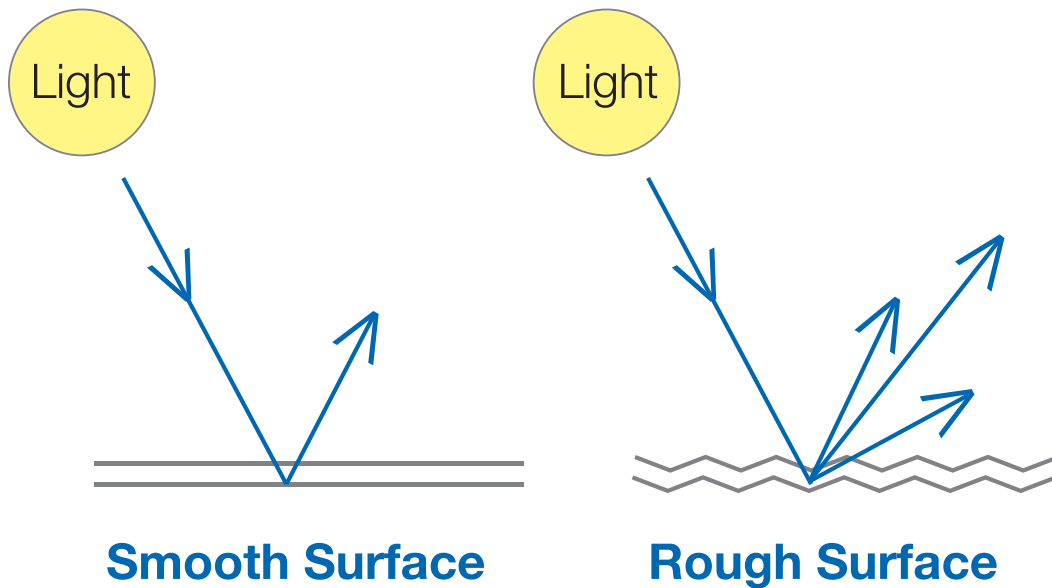

Color matching is accomplished by hiding the differences.

## Recommended Welding Parameters

### Square - Groove Weld

Nominal Plate Thickness		Gap		Filler Wire Diameter		Amps	Volts	Wire Speed		Travel Speed		Wire Consumption		
in.	mm	in.	mm	in.	mm			ipm	m/min	ipm	cm/min	lbs/100 ft.	kg/m	
5/64	(.078)	2	0	0	.030	0.8	80	18-21	460	11.7	40	102	0.67	.01
1/8	(.125)	3	0-1/32	0-0.5	.035	0.9	130	19-22	480	12.2	40	102	0.75	.01
5/32	(.156)	4	0-3/64	0-1	.040	1.0	160	20-23	450	11.4	40	102	1.25	.02

### Single V-Groove

(typical included groove angle = 60°)

Nominal Plate Thickness		Gap		Filler Wire Diameter		Amps	Volts	Wire Speed		Travel Speed		Wire Consumption		
in.	mm	in.	mm	in.	mm			ipm	m/min	ipm	cm/min	lbs/100 ft.	kg/m	
3/16	(.187)	5	0	0	.035	0.9	175	19-23	750	19.1	40	102	2.6	.04
1/4	(.250)	6	0	0	.047	1.2	195	20-24	430	10.9	40	102	4.6	.07
5/16	(.313)	8	0	0	.047	1.2	220	21-25	465	11.8	35	89	7.2	.11
3/8	(.375)	10	0-1/16	0-1	.062	1.6	240	22-26	320	8.1	35	89	10.3	.15
1/2	(.500)	12	0-1/16	0-1	.062	1.6	275	23-27	380	9.7	30	76	18.3	.27
3/4	(.750)	19	0-3/32	0-2	.071	1.8	290	24-28	335	8.5	24	61	41.3	.61
1	(1.00)	25	0-3/32	0-2	.094	2.4	330	26-32	180	4.6	18	46	73.4	1.09

### Horizontal Fillet Weld

Nominal Plate Thickness		Gap		Filler Wire Diameter		Amps	Volts	Wire Speed		Travel Speed		Wire Consumption		
in.	mm	in.	mm	in.	mm			ipm	m/min	ipm	cm/min	lbs/100 ft.	kg/m	
5/64	(.078)	2	N/A		.030	0.8	100	18-20	500	12.7	41	104	0.4	.01
1/8	(.125)	3	N/A		.035	0.9	140	19-21	580	14.7	31	78	0.6	.01
5/32	(.156)	4	N/A		.040	1.0	150	20-22	425	10.8	20	51	1.6	.02
5/32	(.156)	4	N/A		.047	1.2	180	20-22	410	10.4	25	64	1.6	.02
3/16	(.187)	5	N/A		.047	1.2	190	21-23	425	10.8	22	56	2.2	.03
3/16	(.187)	5	N/A		.062	1.6	220	21-23	285	7.2	26	66	2.2	.03
1/4	(.250)	6	N/A		.047	1.2	210	22-24	480	12.2	20	51	4.0	.06
1/4	(.250)	6	N/A		.062	1.6	230	22-25	300	7.6	25	64	4.0	.06
5/16	(.313)	8	N/A		.062	1.6	230	23-26	300	7.6	20	51	6.2	.09
3/8	(.375)	10	N/A		.062	1.6	240	23-26	325	8.3	18	46	8.9	.13
1/2	(.500)	12	N/A		.071	1.8	280	24-28	335	8.5	24	61	15.9	.24

### Outside Corner Joint

Nominal Plate Thickness		Gap		Filler Wire Diameter		Amps	Volts	Wire Speed		Travel Speed		Wire Consumption		
in.	mm	in.	mm	in.	mm			ipm	m/min	ipm	cm/min	lbs/100 ft.	kg/m	
5/64	(.078)	2	N/A		.030	0.8	80	18-20	460	11.7	40	101.6	0.4	.01
1/8	(.125)	3	N/A		.035	0.9	110	19-21	480	12.2	30	76.2	0.6	.01
5/32	(.156)	4	N/A		.040	1.0	130	20-22	433	11.0	26	66.4	1.6	.02
3/16	(.187)	5	N/A		.047	1.2	155	21-23	365	9.3	22	55.9	2.2	.03
1/4	(.250)	6	N/A		.047	1.2	185	22-24	420	10.7	20	50.8	4.0	.06
5/16	(.313)	8	N/A		.062	1.6	195	23-26	260	6.6	12	30.5	6.2	.09
3/8	(.375)	10	N/A		.062	1.6	230	23-26	300	7.6	8	20.3	8.9	.13
1/2	(.500)	12	N/A		.071	1.8	255	24-28	315	8.0	8	20.3	15.9	.24

**NOTE:** Welding parameters were developed utilizing the GMAW process with 100% argon shielding gas under laboratory conditions and are provided as guidelines only. For 5XXX series electrodes use a welding amperage on the high side of the range and an arc voltage on the lower end of the range. For 1XXX, 2XXX and 4XXX series electrodes use the lower amperage and higher arc voltage.



5083 5456		5086 5056		511.0 512.0 513.0 514.0 5154 5254		5454		6005 6060 6063 6101 6151 6351 6951		6061 6070		7005 7021 7039 7046 710.0 711.0		413.0 443.0 444.0 356.0 A356.0 A357.0 359.0		319.0 333.0 354.0 355.0 C355.0 380.0																																																																		
W	S	D	C	T	M	W	S	D	C	T	M	W	S	D	C	T	M	W	S	D	C	T	M	W	S	D	C	T	M	W	S	D	C	T	M	W	S	D	C	T	M	W	S	D	C	T	M																																			
																																																						2319*																												

### Aluminum Filler Alloy Chart

SYMBOL	CHARACTERISTIC
<b>W</b>	<b>Ease of welding</b> Relative freedom from weld cracking.
<b>S</b>	<b>Strength of welded joint</b> (as-welded condition) Rating applies particularly to fillet welds. All rods & electrodes rated should develop presently specified minimum strengths for butt welds.
<b>D</b>	<b>Ductility</b> Rating is based upon the free bend elongation of the weld.
<b>C</b>	<b>Corrosion resistance</b> in continuous or alternate immersion in fresh or salt water.
<b>T</b>	Recommended for service at <b>sustained temperatures</b> above 150°F (65.5°C).
<b>M</b>	<b>Color match</b> after anodizing.

A, B, C, & D are relative ratings in decreasing order of merit. The ratings have relative meaning only within a given block.

### How To Use This Chart

1. Select base alloys to be joined (one from the side blue column, the other from the top blue row).
2. Find the block where the column and row intersect.
3. This block contains horizontal rows of letters (A, B, C or D) representative of the alloy directly across from them in the filler alloy box at the end of each row. The letters in each line give the A-to-D rating of the characteristics listed at the top of each column – W, S, D, C, T and M (see Legend at right for explanation of each letter).
4. Analyze the weld characteristics afforded by each filler alloy. You will find that you can “trade off” one characteristic for another until you find the filler that best meets your needs.

### Example

If joining base alloys 6061 and 5086; first find the box where the 6061 row and the 5086 column intersect. Then notice that there are no ratings for filler alloys 4043/4047, 4145 or 4643 – this means they are not usually recommended for this base combination.

Filler alloy 5356 has an “A” rating for ductility, but a “B” rating for strength. However, alloy 5556 has an “A” rating for strength, but a “B” rating for ductility. Therefore, it must be decided which attribute has the highest priority.

- \*NOTES:  
 (1) Combinations having no rating are not usually recommended.  
 (2) The following filler alloys are heat-treatable and can produce higher strength weldments after postweld solution heat treatment and aging: 206, 357, 2319, 4008, 4009, 4145, and 4643.  
 (3) An “A” rating for alloy 5083 to 5083 and 5083 to 5456. No rating for alloy 5456 to 5456.  
 (4) 4047 can be used in lieu of 4043. Alloy 4047 provides increased fluidity for welding leak-tight joints, minimizes solidification cracking, and has a slightly higher fillet weld shear strength.

# Education





# School for aluminum welding.

Aluminum welding is a specialized process. Whether you are transitioning from welding other materials, or you are a seasoned veteran, it is always important to understand the latest technologies and best practices. That is why we have developed a range of services to help improve your welding and your bottom line that are available at the AlcoTec facility – or we'll come to you.

- AlcoTec Weld School: Aluminum Welding Technology Theory & Practice – an international program that provides a hands-on approach to welding aluminum alloys
- Welder Qualification Program
- Welder training
- On-site tailored consulting – assisting in the methodology and process of your application
- Weld procedure development via tailored support or Welding Procedure Specifications (WPS)

**“AlcoTec has a very good quality product. They stand behind it.”**

– Joseph Maino, AlcoTec customer

## Training and certification

AlcoTec's Weld School program is designed to incorporate both the theoretical and practical, hands-on approach to the welding of aluminum alloys. The classroom instruction includes an understanding of the theory and general characteristics of the various aluminum alloys and tempers.

Register online at [alcotec.com/weldschool](http://alcotec.com/weldschool).



## Welder Certification and Qualification

CWIs (Certified Welding Inspectors) are often asked to “certify” welders. However, most of these requests should actually be to “qualify” welders. So, what is the difference?

### Certification

According to the AWS (American Welding Society):

“The Certified Welder Program is a performance-based program with no prerequisite courses or certifications required. Final certification will provide “transferable” credentials that you may take with you wherever you go.”

To become “certified”, one has to schedule a visit to an AWS ATF (Accredited Test Facility) and perform the testing there. After the inspection and mechanical testing is complete, the test facility will then submit the documentation to the AWS headquarters for review. If everything is properly completed, and all of the testing is satisfactory, the AWS will issue the welder the certification card.

An AWS “certification” is transferable, meaning any employer must recognize it.

### Qualification

This simply refers to a welder testing to the requirements set forth in an applicable code. For most U.S. applications, this would be an AWS code book. The steps to gain “qualification” are a little simpler than certification.

Basically, one must insure the welding, inspection, and mechanical testing are conducted in accordance with the respective code. This does not necessarily require a CWI, but an independent CWI is generally contracted to assist. One reason is to remove any conflict of interest within the organization conducting the testing. The other reason is to insure the person “qualifying” the work has passed the testing requirements set forth by the AWS to properly interpret the code.

A welder qualification is governed and maintained by the manufacturing facility and may or may not be recognized by another employer.

## AlcoTec School of Aluminum Welding Technology

AlcoTec's **School of Aluminum Welding Technology: Theory & Practice Program** is designed to incorporate both a theoretical and practical approach to welding aluminum alloys.

Designed for welding engineers, product design engineers, and sales personnel, the AlcoTec School of Aluminum Welding Technology Program includes comprehensive classroom instruction combined with hands-on laboratory applications.

In this three-day program, students learn metal preparation, weld procedures, inspection procedures, processes for joining aluminum and much more. AlcoTec's staff of Metallurgical, Welding, and Quality Engineers and Technicians bring their years of aluminum manufacturing experience to this program, which educates participants in the theory and general characteristics of various aluminum alloys and tempers.

In addition, AlcoTec is pleased to offer the first program for Aluminum Welding Technology designed specifically for welding instructors. The Aluminum Welding Technology Instructor's Course provides welding instructors with the information and tools they need to effectively introduce their students to aluminum welding.



### What You Will Learn

- Metal preparation
- Weld procedures
- Workmanship
- Inspection procedures
- Understanding welding equipment
- Processes for joining aluminum

### Who Should Attend

- Welding Engineers
- Welding Supervisors
- Welding Instructors
- Product Design Engineers
- Sales Managers and Representatives



## AlcoTec School of Aluminum Welding Technology Course Outline

### Classroom

#### Introduction to Aluminum Welding

- Historical perspective
- Industry information

#### The MIG (GMAW) Welding Process

- Transfer modes
- Welding power sources
- Shielding gases
- Wire feedability

#### The TIG (GTAW) Welding Process

- Current types
- Applications
- Procedures

#### Metal Preparation for Welding

- Storage and handling
- Cutting, beveling, and gouging
- Cleaning techniques
- Moisture control

#### Welding Procedures

- Joint design
- Machine settings
- Weld profiles

#### Alloy and Temper Designation System

- Alloying elements
- Wrought alloys
- Cast alloys
- Temper designations

#### Welding Metallurgy

- Heat-treatable and non heat-treatable alloys
- Weld metal composition
- Physical properties

#### Quality Control

- Code and standard requirements
- Welder and welding qualification procedures
- Acceptance criteria
- Testing methods
- Defect measurement

#### Design for Welding

- Applications
- Mechanical properties
- Design considerations
- Distortion control
- Life cycle monetization

---

### Laboratory

#### Equipment Evaluation

- Drive roll geometry
- Liners and guides
- Contact tips
- MIG and TIG set up

#### Welding Test Samples

- Beveling and pre-cleaning
- Welding with MIG and TIG processes

#### Welding Inspection and Testing

- Visual inspection
- Fillet weld fracture tests
- Macros
- Bend tests
- Dye penetrant testing
- X-Ray evaluation

#### Test Results and Code Requirements

- Undercut, overlap, and weld profile evaluation
- Fusion and penetration limits
- Porosity limits

Visit [alcotec.com/weldschool](http://alcotec.com/weldschool) for more information.



# Your aluminum partner.

To learn more about what AlcoTec can do for you,  
call 1.800.228.0750 or visit [alcotec.com](http://alcotec.com).

AlcoTec Wire Corporation  
2750 Aero Park Drive  
Traverse City, MI 49686-9263



[facebook.com/alcotecwire](https://facebook.com/alcotecwire)



[alcotec.com](http://alcotec.com) | 1.800.228.0750  
A member of the ESAB Group, Inc.